

LEGEND

- A** ext. max width at shoulders
- B** seat bottom to mid shoulders
- C** ext. max width of side bolsters
- D** tot. height of seat back
- E** seat bottom max width
- F** seat inner width (belt holes area)
- W** = side fixing (289 mm)
- Y** = bottom fixing (345x270 mm)

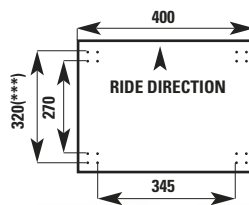

HA/776E/N
sliding brackets

SHELL	MEASURE IN MM						HARNESSESLOT	FIXING			
	A	B	C	D	E	F			HA/719E/N	HA/776T/N	HA/776E/N
STYLE / RAID2											
Tubular steel	560	630	510	970	300	560	3	Y			
DESIGN 2											
Tubular steel	540	640	510	950	310	560	2	Y			
STRADA											
Tubular steel	540	640	510	950	310	560	2	Y			
RALLYE											
Tubular steel	580	610	490	900	350	480+22	4	W+Y			

SEAT MOUNTING EXAMPLES

Seat with lower attachments points

- 1 Sliding brackets (HC/665)
- 2 Optional seat bracket spacer (HC/857 or HC/858)
- 3 Seat mounting bracket (vehicle specific)

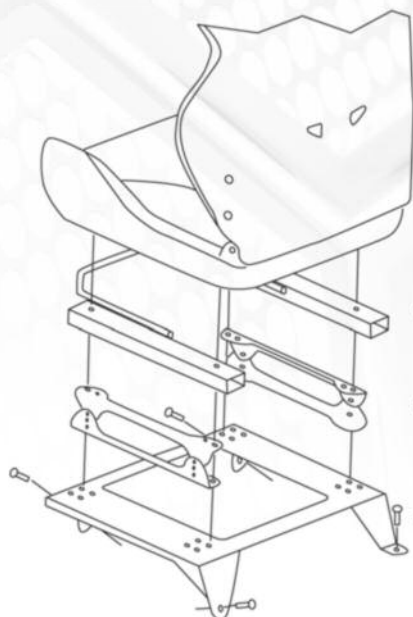

Seat with side attachments points

- 1 Side mounting brackets (Racing)
- 2 Sliding brackets (HC/665)
- 3 Seat mounting bracket (vehicle specific)

