

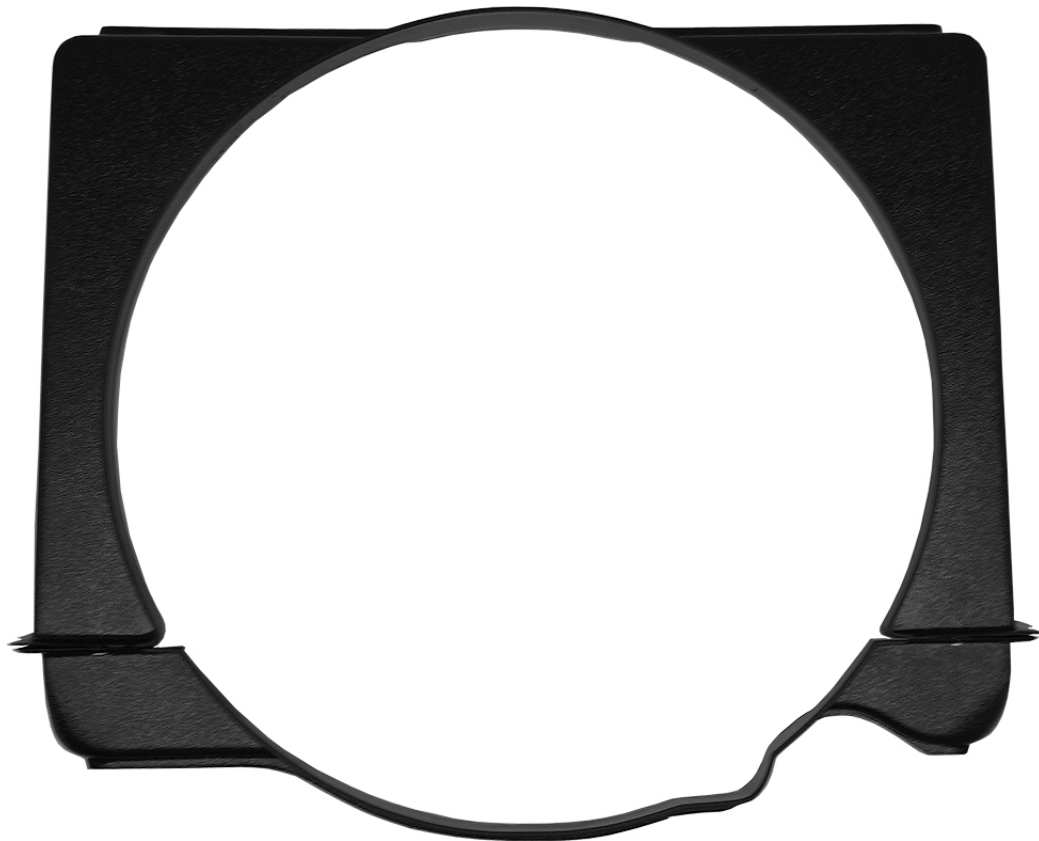

an ISO 9001:2015 Registered Company

1955-57 Chevrolet V8

18" Fan Shroud
(37155-VCF)



18865 Goll St. San Antonio, TX 78266
Phone: 800-862-6658
Sales: sales@vintageair.com
Tech Support: tech@vintageair.com
www.vintageair.com



www.vintageair.com

Table of Contents

Cover.....	1
Table of Contents.....	2
Packing List/Parts Disclaimer.....	3
Core Support Measurements.....	4
Important Information, Engine Compartment Disassembly.....	5
Fan Shroud Installation.....	6
Packing List.....	7



www.vintageair.com

Packing List: Fan Shroud Kit (37155-VCF)

No.	Qty.	Part No.	Description
1.	4	18250-VUB	Screw, 10-32 x 1/2", Pan Head
2.	4	18123-VUB	Washer, 3/16" x 1/2", SAE Flat
3.	1	32802-VCF	Shroud, Fan, Top
4.	1	328030	Shroud, Fan, Bottom

**** Before beginning installation, open all packages and check contents of shipment.
Please report any shortages directly to Vintage Air within 15 days. After 15 days,
Vintage Air will not be responsible for missing or damaged items.**

1



2



3



4



**NOTE: Images may not depict actual parts and quantities.
Refer to packing list for actual parts and quantities.**



www.vintageair.com

Fan Shroud Measurements

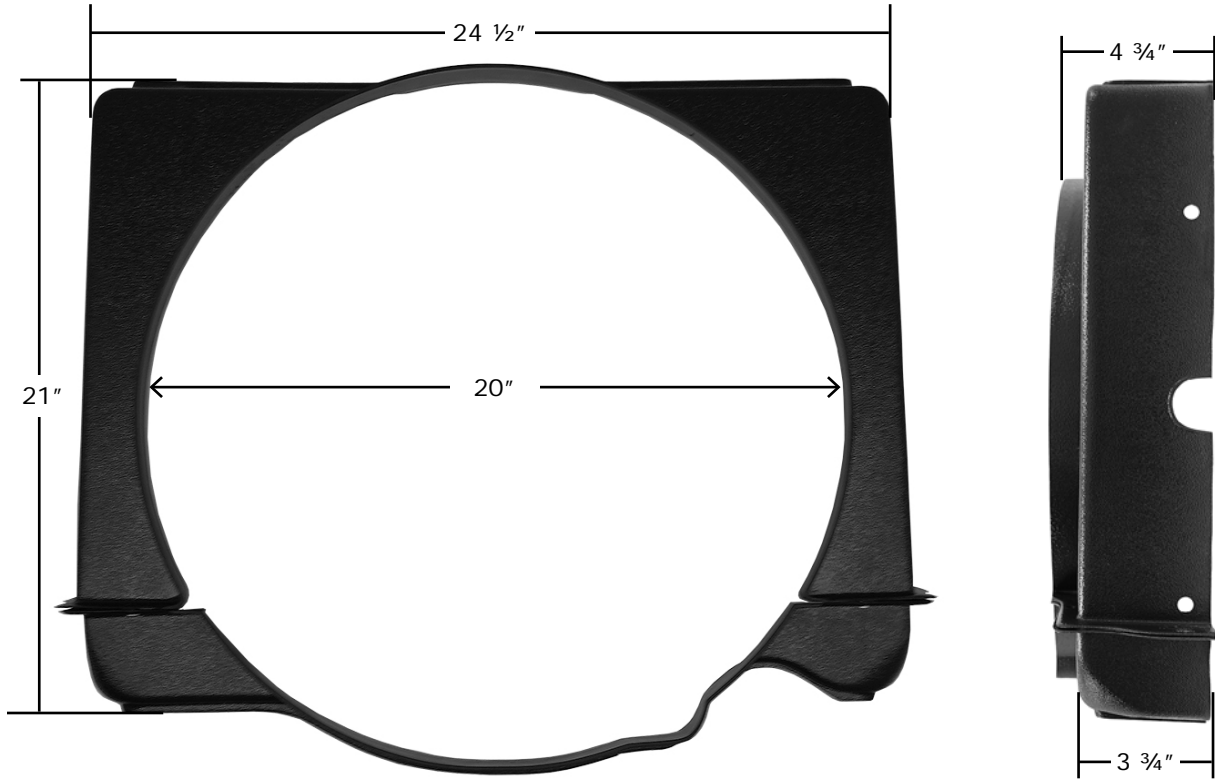



www.vintageair.com

Important Information

- The Vintage Air fan shroud is designed for an 18" heavy duty fan (#32918-VUF).
- With power steering, it may be necessary to space the fan forward 3/8". A spacer kit (#32155-VCF) is available from Vintage Air.

Engine Compartment Disassembly

Remove the Following:

1. Top radiator hose.
2. Radiator top and bottom support bolts (See Figure 1, below). **NOTE: Do not remove the center bolt, this will hold the radiator and condenser in alignment.**

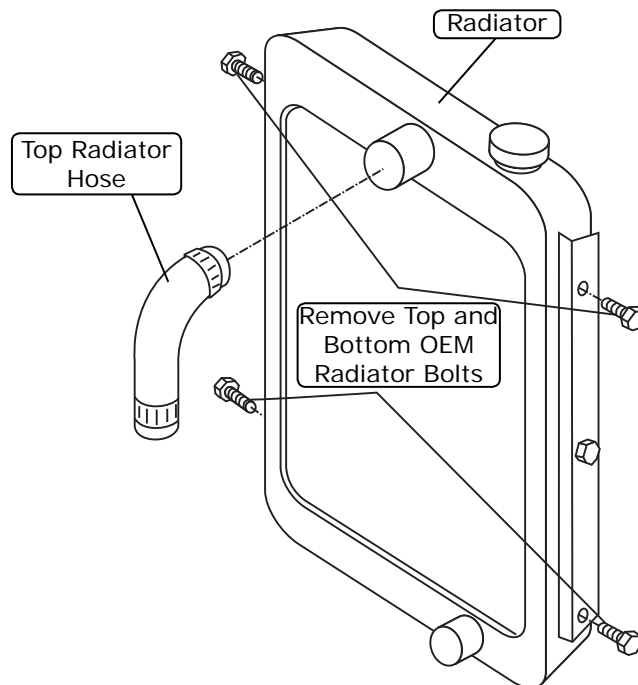

Figure 1



www.vintageair.com

Fan Shroud Installation

1. Insert the bottom half of the fan shroud (See Figure 1, below).
2. Install the top half of the fan shroud to the radiator using (4) OEM radiator support bolts (See Figure 2, below).
3. If applicable, check for clearance at the power steering pump drive pulley. Trim for clearance if necessary.
4. Secure the bottom half of the fan shroud with (4) 10-32 x 1/2" screws and (4) 3/16" x 1/2" SAE flat washers. (See Figure 3, below).
5. Reinstall the radiator top hose.

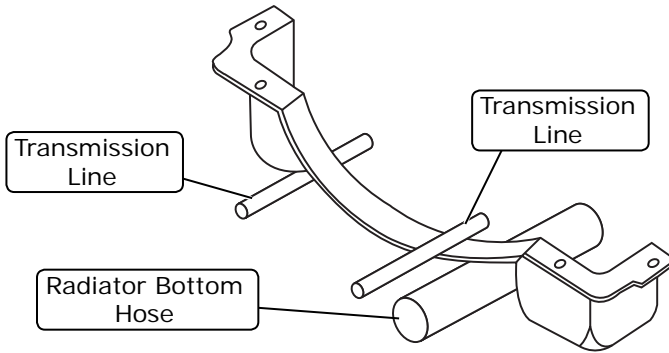

Figure 1

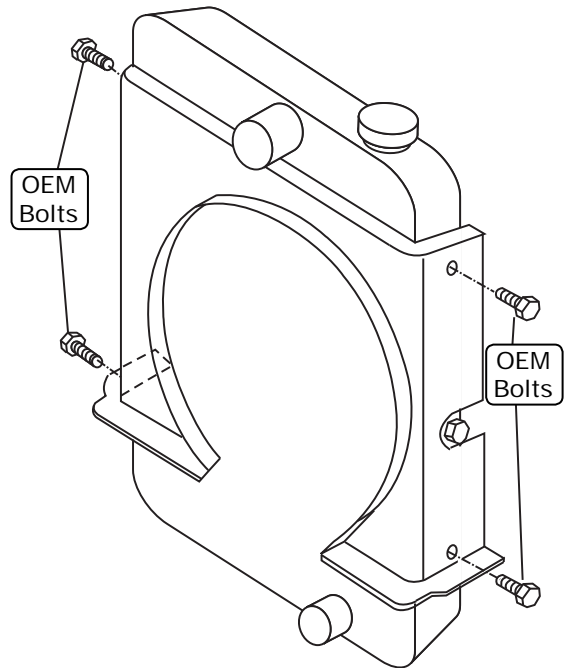

Figure 2

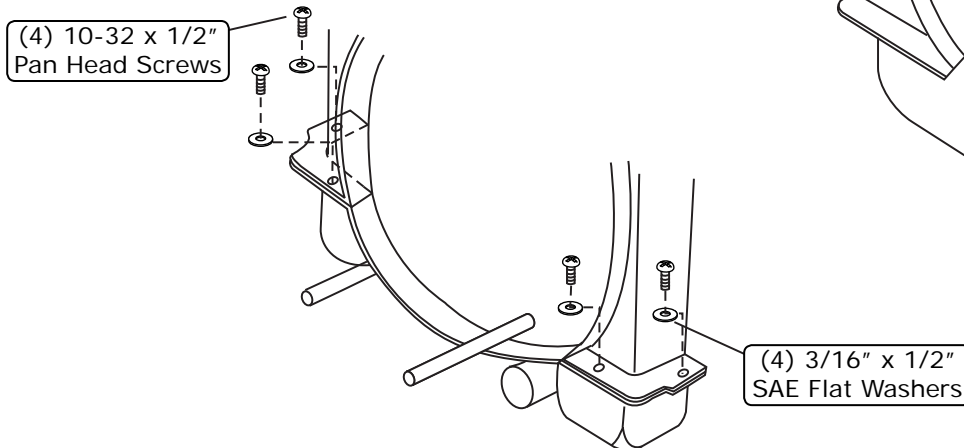

Figure 3



www.vintageair.com

Packing List: Fan Shroud Kit (37155-VCF)

No.	Qty.	Part No.	Description	
1.	4	18250-VUB	Screw, 10-32 x 1/2", Pan Head	_____
2.	4	18123-VUB	Washer, 3/16" x 1/2", SAE Flat	_____
3.	1	32802-VCF	Shroud, Fan, Top	_____
4.	1	328030	Shroud, Fan, Bottom	_____

Checked By: _____
Packed By: _____
Date: _____

1



2



3



4



**NOTE: Images may not depict actual parts and quantities.
Refer to packing list for actual parts and quantities.**