



INSTALLATION INSTRUCTIONS

APPLICATION: 2001 FORD RANGER/RANGER EDGE
 1999-01 MAZDA B-SERIES PICK-UP
 2/4 DOOR AND 2/4 WHEEL DRIVE

AUTOMOTIVE PRODUCTS, INC.

SPORTSMAN
 ASSEMBLY:
40-0885

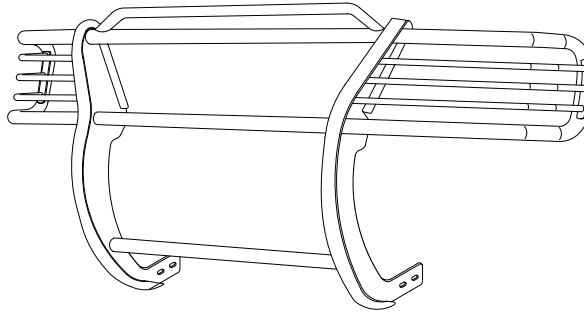

PARTS KIT CONTENTS DESCRIPTION		TOOLS REQUIRED
QTY		
1	SPORTSMAN ASSEMBLY WITH LIGHT GUARDS	3/4" SOCKET
2	MOUNT BRACKET, PASSENGER AND DRIVER	9/16" SOCKET
2	SUPPORT BRACKET, PASSENGER AND DRIVER	1/2" SOCKET
2	MAZDA TOP BRACE, PASSENGER AND DRIVER	13MM SOCKET
2	FORD TOP BRACE, PASSENGER AND DRIVER	10MM SOCKET
4	1/2-13 X 1.25" HEX HEAD BOLT	3/4" WRENCH
2	1/2-13 X 4.00" HEX HEAD BOLT	9/16" WRENCH
4	3/8-16 X 1.25" HEX HEAD BOLT	13MM WRENCH
4	5/16-18 X 1.00" SELF TAPPING BOLT	RATCHET
6	1/2-13 HEX NUT	EXTENSION
4	3/8-16 HEX NUT	TORQUE WRENCH
12	1/2" FLAT WASHER	
6	1/2" SPLIT LOCK WASHER	
8	3/8" FLAT WASHER	
4	3/8" SPLIT LOCK WASHER	
2	BACKING PLATE	
		NOTE: FASTENERS ARE CONTAINED IN BOLT KIT 60-1208.

- STEP 1. Remove the contents from the box and check for any damage. Verify all parts against parts list.
- STEP 2. Read and understand instructions completely before beginning installation.
- STEP 3. Install mount brackets on the outside face of frame members with 1/2-13 x 4.00" hex head bolts. Secure with backing plates and 1/2" fasteners. **See figure 2.** Leave loose.
- STEP 4. Install support brackets using holes in bottom face of vehicle frame using 5/16-18 x 1.00" self tapping bolts. Some vehicles have a plastic shroud mounted to bottom of frame. Remove bolts with 10MM socket. Remove "push type" fastener from shroud. Place support brace against bottom of frame, reinstall shroud with factory bolts. Replace push type connector with 5/16" self tapping bolt. Leave loose. **See figure 1.**
- STEP 5. Secure support bracket to mount bracket using 3/8" fasteners. **See figure 1.**
- STEP 6. Install top brace between bumper and grille on each side. From underneath vehicle, remove 10MM bolt with 13MM socket that is located below headlight on the back side of bumper. Position braces so that they bolt to the outside of sportsman uprights. Reinstall 10MM bolt through top brace. Leave loose. **NOTE:** Ranger uses longer top braces.

- STEP 7. With sportsman front side down in front of vehicle, bolt rear slot of sportsman up to rear slot of mount bracket. Leave loose. Rotate sportsman up to vehicle and bolt remaining 1/2" and 3/8" fasteners. Leave loose. **See figure 1.**
- STEP 8. Center and level sportsman as desired and torque all fasteners: 1/2" to 65 FT. LBS; 5/16 and 8MM to 15 FT. LBS and 10MM to 35 FT. LBS.

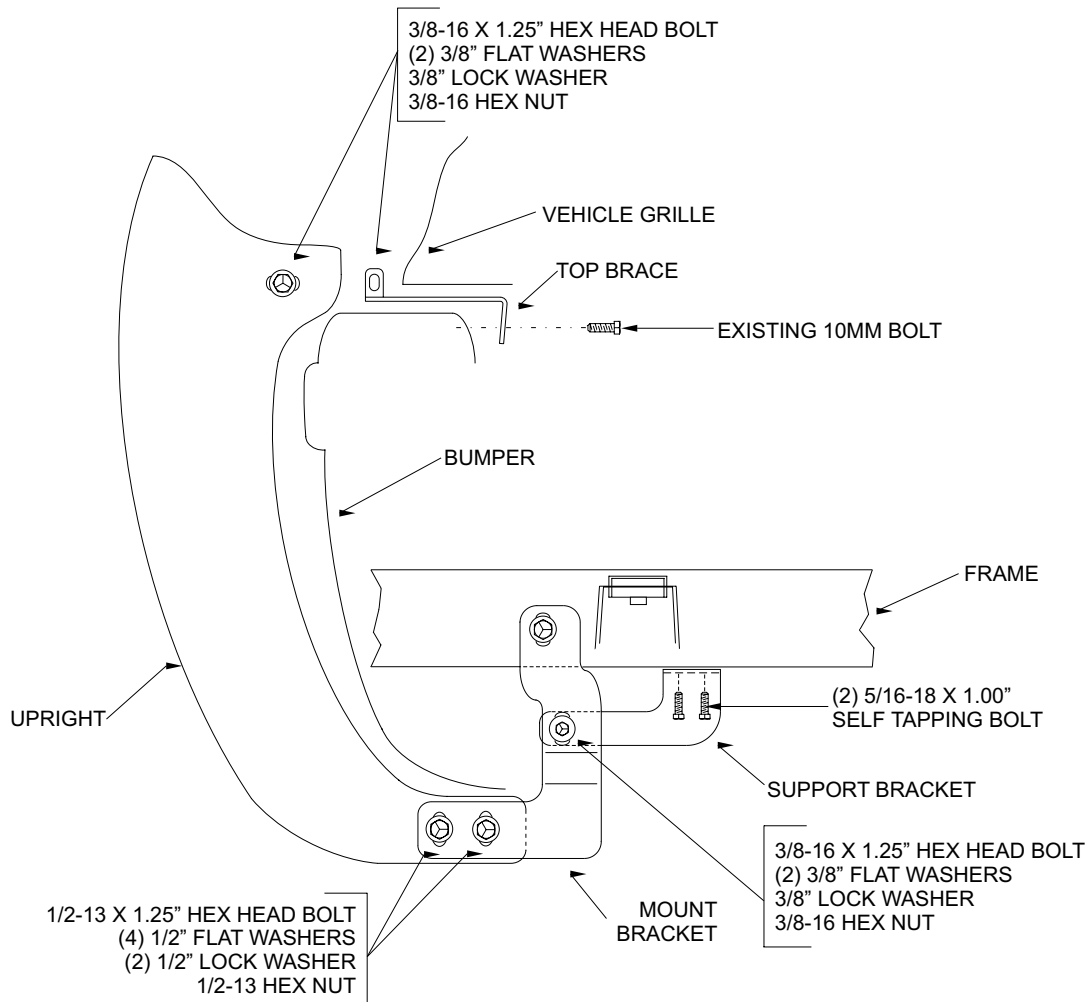
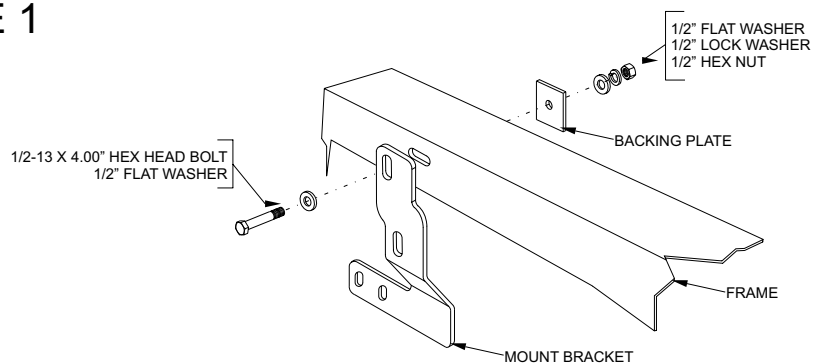

FIGURE 1



**INSTALLATION OF DRIVER SIDE
(PASSENGER SIDE OPPOSITE)**

FIGURE 2

Finish protection - Westin products have a high quality finish that must be cared for like a other exposed finish on the vehicle. Protect the finish with a non-abrasive automotive w (pure carnauba, for example) on a regular basis. The use of cleaner wax or any compound wh contains an abrasive is detrimental, as the compounds scratch the finish and open it to corrosio



Westin Automotive Products, Inc.
5200 N. Irwindale Ave. Suite 220
Irwindale, Ca. 91706

Thank You for choosing Westin products
For additional installation assistance please call
Customer service (800) 793-7846 or (507) 375-3559