



## Chevrolet Camaro 2010-2015

Visit [MetraOnline.com](http://MetraOnline.com) for more detailed information about the product and up-to-date vehicle specific applications

### KIT FEATURES

- ISO DIN radio provision with pocket
- ISO DDIN radio provision
- Painted silver to match the factory finish
- Repurposes the factory climate knobs for a factory look and feel
- Includes an Axxess interface, wiring harness, and antenna adapter

### KIT COMPONENTS

- A) Radio trim panel (with preassembled circuit board)
- B) Radio brackets
- C) Pocket
- D) #4 x 3/8" Phillips pan-head screws (8)
- E) #8 x 3/8" Phillips truss-head screws (4)
- F) Axxess interface and wiring (not shown)
- G) Antenna adapter (not shown)

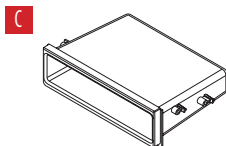
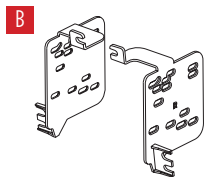
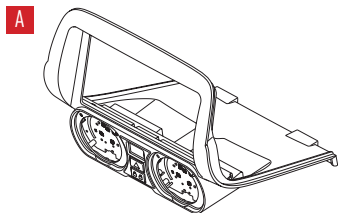

### TABLE OF CONTENTS

Dash Disassembly .....	2-3
Kit Preparation .....	4-7
Kit Assembly	
–ISO DIN radio provision with pocket .....	8
–ISO DDIN radio provision .....	8
Axxess Interface Installation .....	9-19
Final Assembly .....	15

### WIRING & ANTENNA CONNECTIONS

Wiring Harness: Axxess interface included  
 Antenna Adapter: Included with kit  
 Steering wheel control interface: Included with kit  
 Backup camera retention: BACKUPCAM-2 (sold sep.)  
 Personalization Menu LCD: AX-LCD (sold sep.)

### TOOLS REQUIRED

- Panel removal tool
- Phillips #1 screwdriver
- Phillips #2 screwdriver
- 9/32" socket wrench
- T-20 Torx screwdriver
- Cutting tool

**Attention!** Let the vehicle sit with the key out of the ignition for a few minutes before removing the factory radio. When testing the aftermarket equipment, ensure that all factory equipment is connected before cycling the key to ignition.

## DASH DISASSEMBLY

**For vehicles without UMQ gauge panel, unsnap and remove shifter trim panel and skip to step 8.**

1. Unclip and remove the (2) side trim panels running the length of the center console. (Figure A)
2. Remove (1) Phillips screw from each side of the front of the center console. (Figure B)
3. Remove (2) Phillips screws per side from the cover on the back of the center console then unclip and remove the cover. (Figure C)

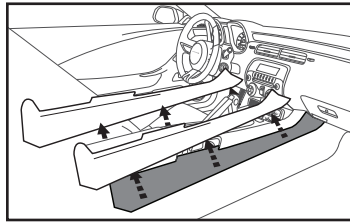

(Figure A)

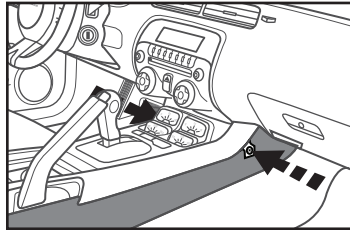

(Figure B)

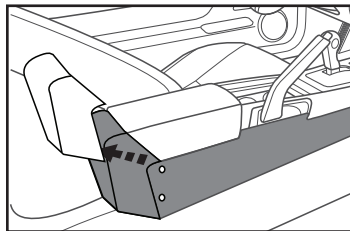

(Figure C)

4. Remove (2) Phillips screws exposed under the cover on the back of console. (Figure D)
5. Remove gauge cluster/trim panel around shifter. (Figure E)
6. **Auto transmission vehicles only:** Remove one T-20 Torx screw from the front of the shifter, and then remove the knob and shifter surround panel. (Figure F)

*Continue onto next page*

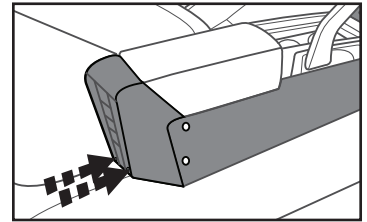

(Figure D)

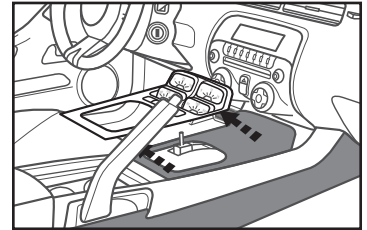

(Figure E)

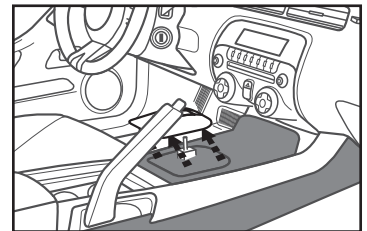

(Figure F)

## DASH DISASSEMBLY (CONT.)

7. Remove (4) Phillips screws now exposed, and then lift up on the rear of the center console. Slide toward the back of the vehicle then unclip and remove the entire center console. (Figure G)
8. Remove (2) 9/32" screws securing the climate control/radio trim panel and remove. (Figure H)
9. Remove (4) 9/32" screws securing the radio chassis, and then remove. (Figure I)

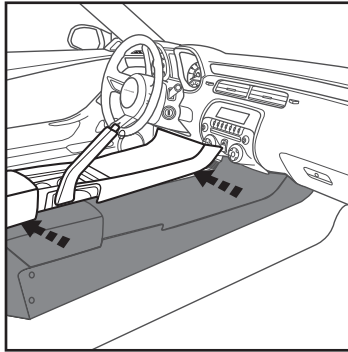

(Figure G)

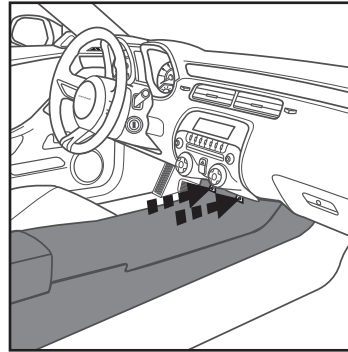

(Figure H)

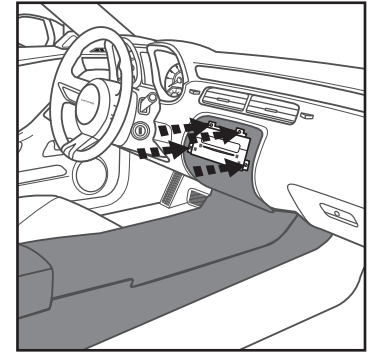

(Figure I)

*Continue to Kit Preparation*

## KIT PREPARATION

**Attention!** Due to how involving it is to disassemble the factory radio, it is highly advisable to read the steps beforehand to get a clear understanding of what is to be expected. It would be best if pictures are taken during the process, and all hardware tagged as the process seems too complex, it is best to seek a professional to perform the job. Also take care when handling the circuit board to avoid static discharge which will damage the circuit board.

### From the factory radio:

1. If not already, turn both climate knobs to the far left.
2. Remove all the Phillips screws securing the cover to the back of the radio, then unplug and remove the cover.
3. Remove (8) screws securing the (2) plastic gear mechanisms. (Figure A)
4. Remove (4) Phillips screws securing the (2) climate knobs. (Figure A)
5. Press in on (2) tabs to remove each climate knob from the front. (Figure A)
6. From the front, remove (2) Phillips screws in each climate knob cavity. (Figure B)
7. Remove the (2) plastic gear mechanisms.

*Continued on the next page*

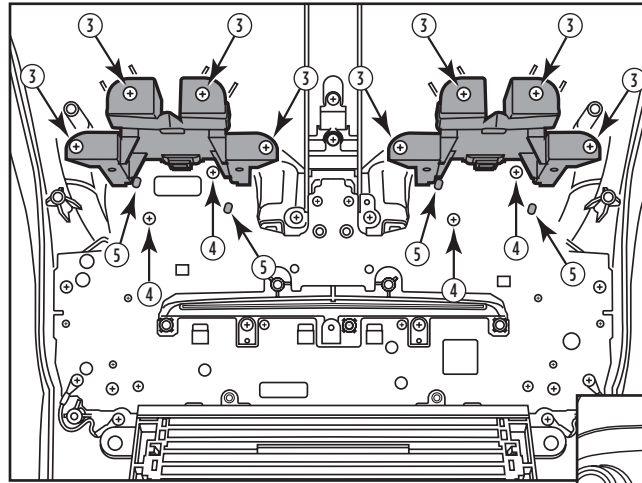

(Figure A)

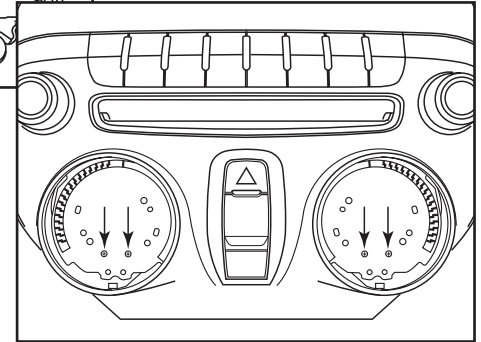

(Figure B)

## KIT PREPARATION (CONT.)

### To the 99-3028S radio trim panel:

8. Remove (6) screws securing the **circuit board cover**, then remove the cover. (Figure C)
9. Carefully remove the **circuit board** from the panel. (Figure D)
  - (a) If the **button membrane** came loose, place it back on by setting it on top of the (3) locater pins.
  - (b) If the **climate display** came loose, place it back onto the **circuit board** by lining up the pins in the **circuit board**. (See detail)

Continue to Kit Assembly

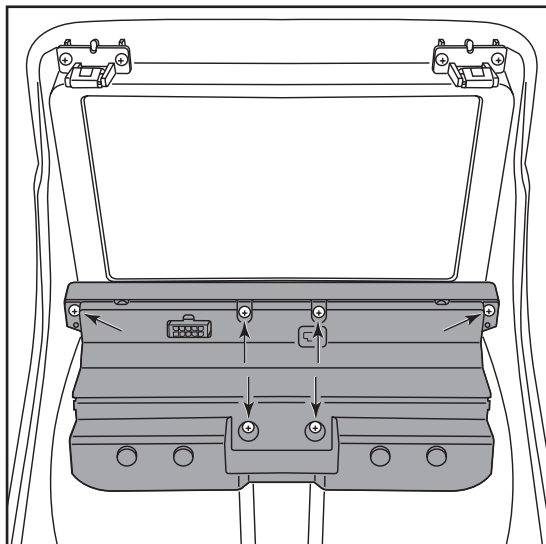

(Figure C)

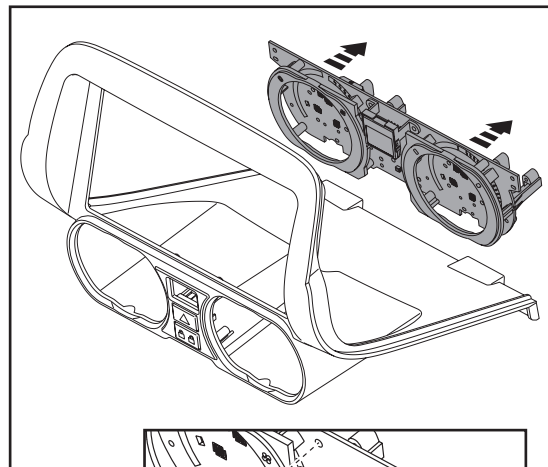

(Figure D)

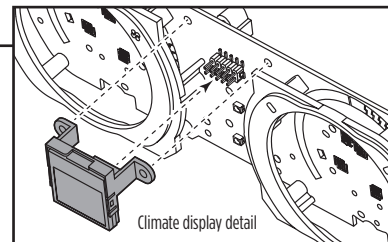

## KIT PREPARATION (CONT.)

- Line up the (2) locator pins in the gear mechanism to the **circuit board**, and in the same motion, attach it to the **support brace**. Secure it to the **support brace** using (2) #4 X 3/8" Phillips pan-head screws provided. Do the same for both sides. (Figure E)
- Flip the **circuit board** over, then secure the gear mechanism to the **circuit board** using the factory screws. (Figure E)
- One at a time, place the climate knobs into the climate knob cavity, lining it up with the gear mechanism. Make sure they are placed correctly. The "snowflake" button should be placed on the right side (passenger side). Flip the **circuit board** over while holding the knob, then secure it to the **circuit board** using (2) #4 X 3/8" Phillips pan-head screws provided. Do the same for the other knob. (Figure F)

**Note:** The factory screws may also be used.

*Continued on the next page*

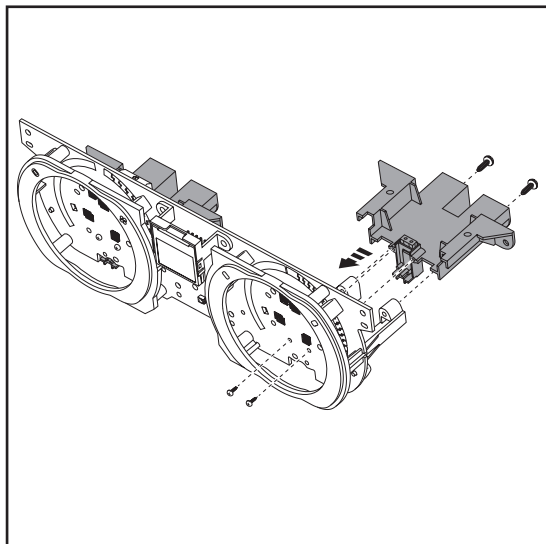

(Figure E)

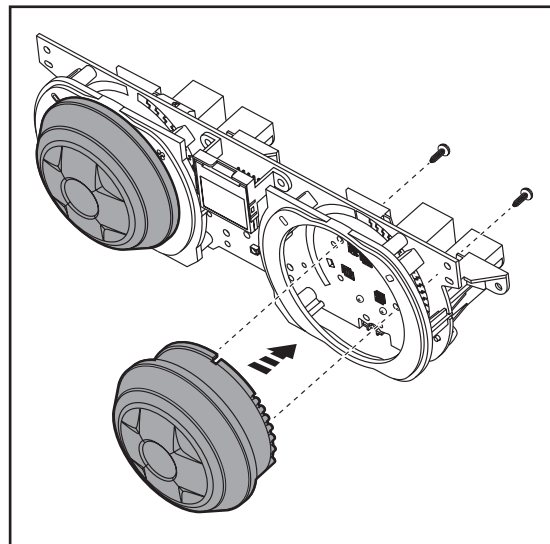

(Figure F)

## KIT PREPARATION (CONT.)

- Carefully place the **circuit board** assembly back into the radio trim panel. If set in correctly, the (4) locator pins will line up and push through the **circuit board**. (Figure G)
- Secure the **circuit board cover** back to the radio trim panel using the screws previously removed. (Figure H)

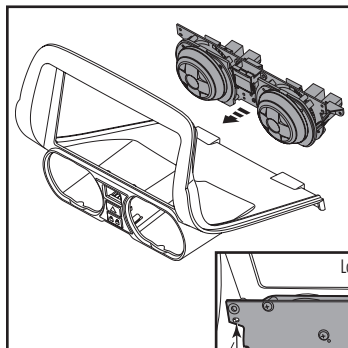

(Figure G)

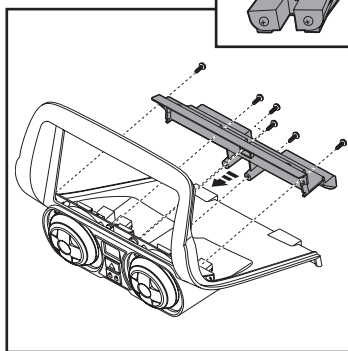
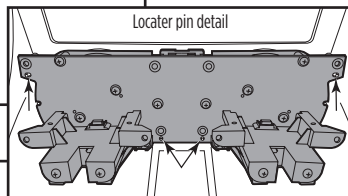

(Figure H)

### Sub-dash modification:

- Cut and remove the sub dash radio support to make room for the interface and harnesses. (Figure I)

*Continue to Kit Assembly*

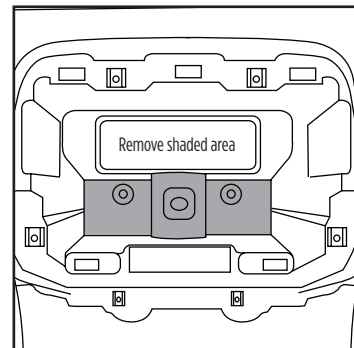

(Figure I)

## KIT ASSEMBLY

### ISO DIN radio provision with pocket

1. Attach the **pocket** to the **radio brackets** using (4) #8 x 3/8" Phillips truss-head screws provided. (Figure A)
2. Remove the metal DIN sleeve and trim ring from the aftermarket radio.
3. Slide the radio into the bracket/pocket assembly, then secure it using the screws supplied with the radio. (Figure B)

Continue to Axxess Interface Installation.

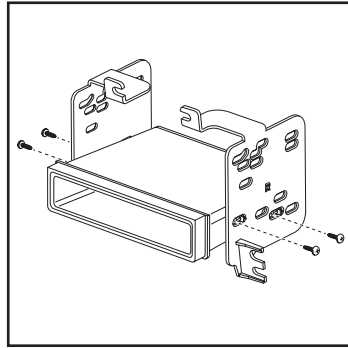

(Figure A)

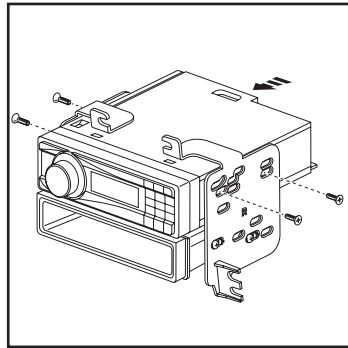

(Figure B)

### ISO DDIN radio provision

1. Secure the **radio brackets** to the radio using the screws supplied with the radio. (Figure A)

Continue to Axxess Interface Installation.

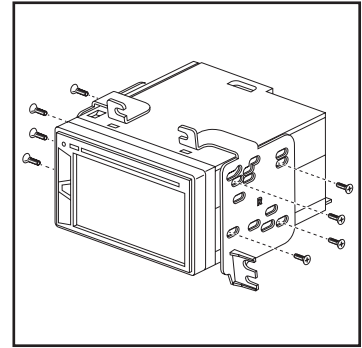

(Figure A)



# AXXESS INTERFACE INSTALLATION

## INTERFACE FEATURES

---

- Provides accessory power (12-volt 10-amp)
- Maintains the Retained Accessory Power (R.A.P.) feature
- Provides NAV outputs (parking brake, reverse, speed sense)
- Retains warning chimes
- Retains OnStar/OE Bluetooth
- Adjustable volume for chimes and OnStar
- Retains the factory AUX-IN jack
- Retains audio controls on the steering wheel
- Can be used in non-amplified, or amplified models
- Retains balance and fade
- Micro-B USB updatable

## INTERFACE COMPONENTS

---

- Axxess interface
- 3028 harness
- Climate control harness
- 16-pin harness with stripped leads
- 4-pin to 4-pin resistor pad harness
- Female 3.5mm connector with stripped leads

## TABLE OF CONTENTS

---

Connections .....	10-13
For models <i>without</i> an amplifier .....	10-11
For models <i>with</i> an amplifier .....	12-13
Installation .....	13
Programming .....	14
Adjustments .....	14
Steering Wheel Control Settings .....	16-18
Troubleshooting .....	19

## TOOLS REQUIRED

---

- Crimping tool and connectors, or solder gun, solder, and heat shrink
- Small flat blade screwdriver • Tape • Wire cutter • Zip ties

**Attention!** This interface will work with models that are either non-amplified or amplified, Please follow the instructions carefully for your model vehicle. Failure to do so will result in either no sound, or low sound. If you are unsure if your vehicle is factory amplified or not, please contact your local dealership.

### For models *without* an amplifier:

#### From the 16-pin harness with stripped leads to the aftermarket radio:

- Connect the **Red** wire to the accessory wire.  
**Note:** If installing either an ASWC-1 or AX-LCD (both sold separately), connect the (2) **Red** wires from the **3028 harness** as well.
- If the aftermarket radio has an illumination wire, connect the **Orange/White** wire to it.
- If the aftermarket radio has a mute wire, connect the **Brown** wire to it. If the mute wire is not connected, the radio will turn off when OnStar is activated.
- Connect the **Gray** wire to the right front positive speaker output.
- Connect the **Gray/Black** wire to the right front negative speaker output.
- Connect the **White** wire to the left front positive speaker output.
- Connect the **White/Black** wire to the left front negative speaker output.

The following (3) wires are only for multimedia/navigation radios that require these wires.

- Connect the **Blue/Pink** wire to the VSS/speed sense wire.
- Connect the **Green/Purple** wire to the reverse wire.
- Connect the **Light Green** wire to the parking brake wire.
- Tape off and disregard the following (5) wires, they will not be used in this application:  
**Blue/White, Purple, Purple/Black, Green, Green/Black**

#### From the 3028 harness to the aftermarket radio:

- Connect the **Black** wire to the ground wire.
- Connect the **Yellow** wire to the battery wire.
- Connect the **Pink** wire with a red bullet connector to the **Pink** wire from the **climate control harness**. If this wire is not connected the climate control will fail to function.
- If installing either an ASWC-1 or AX-LCD (both sold separately), connect the (2) **Red** wires to accessory power.
- Cut off and remove the resistors from the **Green, Green/Black, Purple, and Purple/Black** wires below the heat shrink.
- Connect the **Green** wire to the left rear positive speaker output.
- Connect the **Green/Black** wire to the left rear negative speaker output.
- Connect the **Purple** wire to the right rear positive speaker output.
- Connect the **Purple/Black** wire to the right rear negative speaker output.
- Ensure the (2) 4-pin Molex connectors are connected together.

**Note:** The 4-pin to 4-pin resistor pad harness *will not* be used in this application.

*Continued on the next page*

## CONNECTIONS (CONT.)

- The **Black/Yellow** wire is used for OnStar level adjustment for models that do not come equipped with steering wheel controls. Refer to the **OnStar level Adjustment** section for further instructions.
- If retaining the factory AUX-IN jack is desired, connect the **Red** and **White** RCA jacks to the audio AUX-IN jacks from the aftermarket radio.

### Note:

- a) The jack can only be used if it is a single jack.
- b) If the jack has a USB port as well, neither can be retained.

**Note:** The relay attached to the **3028 harness** is only for audible turn signal clicks. No extra steps are required to retain this feature, so leave the relay as-is.

### DIN jack:

The DIN jack is to be used with the optional AX-LCD (sold separately) to retain the personalization menu.

*Continue to Installation*

### For models *with* an amplifier:

#### From the 16-pin harness with stripped leads to the aftermarket radio:

- Connect the **Red** wire to the accessory wire.  
**Note:** If installing either an ASWC-1 or AX-LCD (both sold separately), connect the (2) **Red** wires from the **3028 harness** as well.
- Connect the **Blue/White** wire to the amp turn on wire. This wire must be connected to hear sound from the factory amplifier.
- If the aftermarket radio has an illumination wire, connect the **Orange/White** wire to it.
- If the aftermarket radio has a mute wire, connect the **Brown** wire to it. If the mute wire is not connected, the radio will turn off when OnStar is activated.
- Connect the **Gray** wire to the right front positive speaker output.
- Connect the **Gray/Black** wire to the right front negative speaker output.
- Connect the **White** wire to the left front positive speaker output.
- Connect the **White/Black** wire to the left front negative speaker output.

*The following (3) wires are only for multimedia/navigation radios that require these wires.*

- Connect the **Blue/Pink** wire to the VSS/speed sense wire.
- Connect the **Green/Purple** wire to the reverse wire.
- Connect the **Light Green** wire to the parking brake wire
- Tape off and disregard the following (4) wires, they will not be used in this application:  
**Green, Green/Black, Purple, Purple/Black**

*Continued on the next page*

### From the 3028 harness to the aftermarket radio:

- Connect the **Black** wire to the ground wire.
- Connect the **Yellow** wire to the battery wire.
- Connect the **Pink** wire with a red bullet connector to the **Pink** wire from the **climate control harness**. If this wire is not connected the climate control will fail to function.
- If installing either an ASWC-1 or AX-LCD (both sold separately), connect the (2) **Red** wires to accessory power.
- Connect the **Green** wire to the left rear positive speaker output.
- Connect the **Green/Black** wire to the left rear negative speaker output.
- Connect the **Purple** wire to the right rear positive speaker output.
- Connect the **Purple/Black** wire to the right rear negative speaker output.
- Disconnect the (2) 4-pin Molex connectors and then attach the **4-pin to 4-pin resistor pad harness**.

### 3.5mm jack steering wheel control retention:

- The 3.5mm jack is to be used to retain audio controls on the steering wheel control.
- **For the radios listed below:** Connect the **female 3.5mm connector with stripped leads**, to the male 3.5mm SWC jack from the **3028 harness**. Any remaining wires tape off and disregard:
  - **Eclipse:** Connect the steering wheel control wire, normally **Brown**, to the **Brown/White** wire of the connector. Then connect the remaining steering wheel control wire, normally **Brown/White**, to the **Brown** wire of the connector.
  - **Metra OE:** Connect the steering wheel control Key 1 wire (**Gray**) to the **Brown** wire.
  - **Kenwood or select JVC with a steering wheel control wire:** Connect the **Blue/Yellow** wire to the **Brown** wire.
    - Note:** If the **Kenwood** radio auto detects as a JVC, manually set the radio type to **Kenwood**. See the instructions under **Changing Radio Type**.
  - **XITE:** Connect the steering wheel control SWC-2 wire from the radio to the **Brown** wire.
  - **Parrot Asteroid Smart or Tablet:** Connect the 3.5mm jack into the AX-SWC-PARROT (sold separately), and then connect the 4-pin connector from the AX-SWC-PARROT into the radio.
    - Note:** The radio must be updated to rev. 2.1.4 or higher software.
  - **Universal “2 or 3 wire” radio:** Connect the steering wheel control wire, referred to as Key-A or SWC-1, to the **Brown** wire of the connector. Then connect the remaining steering wheel control wire, referred to as Key-B or SWC-2, to the **Brown/White** wire of the connector. If the radio comes with a third wire for ground, disregard this wire.
    - Note:** After the interface has been programmed to the vehicle, refer to the manual provided with the radio for assigning the SWC buttons. Contact the radio manufacturer for more information.
- **For all other radios:** Connect the 3.5mm jack from the 3028 harness, into the jack on the aftermarket radio designated for an external steering wheel control interface. Please refer to the aftermarket radios manual if in doubt as to where the 3.5mm jack goes to.

## CONNECTIONS *(CONT.)*

- The **Black/Yellow** wire is used for OnStar level adjustment for models that do not come equipped with steering wheel controls. Refer to the **OnStar level Adjustment** section for further instructions.
- If retaining the factory AUX-IN jack is desired, connect the **Red** and **White** RCA jacks to the audio AUX-IN jacks from the aftermarket radio.

### **Note:**

- a) The jack can only be used if it is a single jack.
- b) If the jack has a USB port as well, neither can be retained.

**Note:** The relay attached to the **3028 harness** is only for audible turn signal clicks. No extra steps are required to retain this feature, so leave the relay as-is.

### **DIN jack:**

The DIN jack is to be used with the optional AX-LCD (sold separately) to retain the personalization menu.

*Continue to Installation*

## INSTALLATION

### **With the key in the off position:**

1. Connect the **16-pin harness with stripped leads**, and the **3028 harness**, into the Axxess interface.
2. Connect the **climate control harness** to the **radio trim panel**, then to the wiring harness in the vehicle.
3. Locate the factory antenna connector in the dash and complete all necessary connections to the radio. Use the antenna adapter provided to adapt the factory antenna connector to the aftermarket radio.

**Attention!** Do not connect the **3028 harness** to the wiring harness in the vehicle just yet.

## PROGRAMMING

For the steps below, the L.E.D. located inside the interface can only be seen while active. The interface does not need to be opened to see the L.E.D.

1. Start the vehicle.
2. Connect the **3028 harness** to the wiring harness in the vehicle.
3. The L.E.D. will initially turn on solid **Green**, then turn off for a few seconds while it auto detects the radio installed.
4. After a couple seconds the L.E.D. will turn on solid **Red** while the interface auto detects the vehicle. The radio will shut off at this point. This process should take 5 to 30 seconds.
5. Once the vehicle has been auto detected by the interface, the L.E.D. will turn on solid **Green**, and the radio will come back on, indicating programming was successful.

### Programming the climate display:

6. Ensure that the vehicle is still running.
7. Adjust the fan speed on the climate control all the way up, then all the way down.
8. Test all functions of the installation for proper operation, before reassembling the dash.
9. If the interface fails to function, refer to the **Troubleshooting** section.

**Note:** The L.E.D. will turn on solid **Green** for a moment, and then turn off under normal operation after the key has been cycled.

## ADJUSTMENTS

### Chime level adjustment:

1. With the vehicle on, turn it off and leave the keys in ignition. Open the driver's door; chimes will be heard.
2. Wait 10 seconds, and then with a small flat-blade screwdriver, turn the potentiometer clockwise to raise the chime level; counterclockwise to lower the chime level.
3. When the chime is at a desired level, remove the keys from the ignition. This will lock the chime volume at its current level.

### OnStar level adjustment:

1. Press the OnStar button to activate it.
2. While OnStar is speaking, press the VOLUME-UP or VOLUME-DOWN button on the steering wheel to raise or lower the OnStar level.
3. If the vehicle doesn't come equipped with steering wheel controls, locate the **Black/Yellow** wire on the **3028 harness**.
4. While OnStar is speaking, tap the **Black/Yellow** wire to ground. Once the OnStar level is set, it will stay at that level until the **Black/Yellow** wire is tapped to ground again.

## FINAL ASSEMBLY

1. Secure the radio assembly to the dash using the factory screws. (Figure A)
2. Reassemble the dash in reverse order of disassembly using the **99-3028S radio trim panel** to complete the installation. (Figure B)

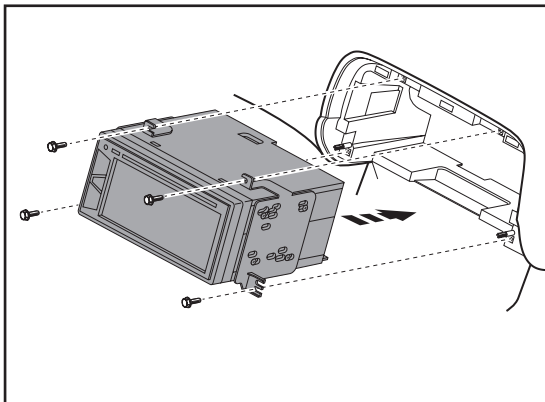

(Figure A)

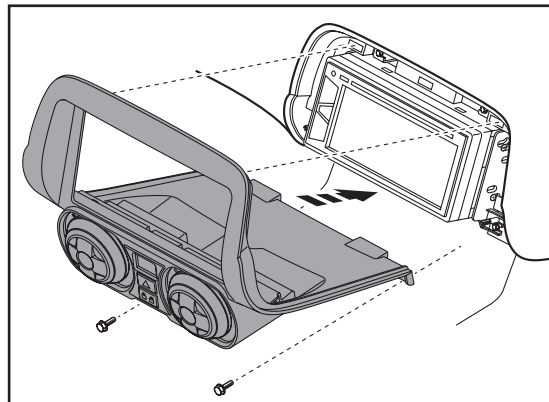

(Figure B)

# STEERING WHEEL CONTROL SETTINGS

## L.E.D. feedback

The (up to 21) **Red** L.E.D. flashes represent what brand radio the Axxess interface believes it is connected to. Each flash represents a different radio Manufacturer. For example, if you are installing a JVC radio, the Axxess interface will flash **Red** (5) times, and then stop. Following is a legend that dictates which radio Manufacturer corresponds to which flash.

## L.E.D. feedback legend

1 flash - Eclipse (Type 1) †	8 flashes - Visteon	15 flashes - XITE
2 flashes - Kenwood ‡	9 flashes - Valor	16 flashes - Philips
3 flashes - Clarion (Type 1) †	10 flashes - Clarion (Type 2) †	17 flashes - TBA
4 flashes - Dual / Sony	11 flashes - Boss (Type 2)	18 flashes - JBL
5 flashes - JVC	12 flashes - Eclipse (Type 2) †	19 flashes - Insane Audio
6 flashes - Boss (Type 1) / Jensen / Pioneer	13 flashes - LG	20 flashes - Axxera / Magnadyne
7 flashes - Alpine *	14 flashes - Parrot **	21 flashes - Boss (Type 3)

\* **Note:** If the Axxess interface flashes **Red** (7) times, and you do not have an Alpine radio connected to it, that means the Axxess interface does not detect a radio connected to it. Verify that the 3.5mm jack is connected to the correct steering wheel jack/wire in the radio.

\*\* **Note:** The AX-SWC-PARROT is required (sold separately). Also, the Parrot radio must have rev. 2.1.4 or higher software.

† **Note:** If you have a Clarion radio and the steering wheel controls do not work, change the radio type to the other Clarion radio type; same for Eclipse. The following section explains how to do this.

‡ **Note:** If you have a Kenwood radio and the L.E.D. feedback comes back showing as a JVC radio, change the radio type to Kenwood. The following section explains how to do this.

**Attention:** The **Axxess Updater App** can also be used to program the following (3) sub-sections as well, pending that the Axxess interface has been programmed.

## Changing radio type

If the LED flashes do not match the radio you have connected, you must manually program the Axxess interface to tell it what radio it is connected to.

1. After (3) seconds of turning the key on, press and hold the **Volume Down** button on the steering wheel until the L.E.D. in the Axxess interface goes solid.
2. Release the **Volume Down** button; the L.E.D. will go out indicating the Axxess interface is in **Changing Radio Type** mode.
3. Refer to the **Radio Legend** to know which radio number you would like to have programmed.
4. Press and hold the **Volume Up** button until the L.E.D. goes solid, and then release. Repeat this step for the desired radio number you have selected.
5. Once the desired radio number has been selected, press and hold the **Volume Down** button on the steering wheel until the L.E.D. goes solid. The L.E.D. will remain on for about (3) seconds while it stores the new radio information.
6. Once the L.E.D. goes out, the **Changing Radio Type** mode will then end. You can now test the steering control wheel controls.

**Note:** If at any time the user fails to press any button for a period longer than (10) seconds, this process will abort.

*Continued on the next page*



## STEERING WHEEL CONTROL SETTINGS (CONT.)

### Radio legend

Radio legend	7. Alpine	15. XITE
1. Eclipse (type 1)	8. Visteon	16. Philips
2. Kenwood	9. Valor	17. TBD
3. Clarion (type 1)	10. Clarion (type 2)	18. JBL
4. Dual / Dual	11. Boss (type 2)	19. Insane Audio
5. JVC	12. Eclipse (type 2)	20. Axxera / Magnadyne
6. Boss (type 1) / Jensen / Pioneer	13. LG	21. Boss (type 3)
	14. Parrot	

### Remapping the steering wheel control buttons

Once the Axxess interface has been programmed, the button assignment for the steering wheel controls may be reassigned if so desired. For example, if the **Seek Up** button is preferred to be the **Mute** button instead. Follow the steps below to remap the steering wheel control buttons:

1. Ensure the Axxess interface is visible so you can see the L.E.D. flashes to confirm button recognition.

**Tip:** Turning the radio off is recommended.

2. Within the first twenty seconds of turning the ignition on, press and hold the **Volume Up** button on the steering wheel until the L.E.D. goes solid.
3. Release the **Volume Up** button, the L.E.D. will then go out; The **Volume Up** button has now been programmed.
4. Follow the list in the **Button Function Legend** to reference the order in which the steering wheel control buttons need to be programmed.

**Note:** If the next function on the list is not on the steering wheel, press the **Volume Up** button for (1) second until the L.E.D. comes on to skip that function, and then release the **Volume Up** button. This will tell the Axxess interface that this function is not available, and it will move on to the next function.

5. To complete the remapping process, press and hold the **Volume Up** button until the L.E.D. in the Axxess interface goes out.

### Button Function Legend

1. Volume-Up	10. Band
2. Volume-Down	11. Play/Enter
3. Seek-Up/Next	12. PTT (Push to Talk)
4. Seek-Down/Prev	13. On-Hook
5. Source/Mode	14. Off-Hook
6. Mute	15. Fan-Up *
7. Preset-Up	16. Fan-Down *
8. Preset-Down	17. Temp-Up *
9. Power	18. Temp-Down *

\* Not applicable in this application

**Note:** Some radios may not have these commands. Please refer to the manual provided with the radio, or contact the radio manufacturer for specific commands recognized by that particular radio.

*Continued on the next page*

## STEERING WHEEL CONTROL SETTINGS (CONT.)

### Dual assignment instructions (long button press)

The Axxess interface has the capability to assign (2) functions to a single button, except **Volume Up** and **Volume Down**. Follow the steps below to program the button(s) to the desired setting.

**Note:** **Seek Up** and **Seek Down** come pre-programmed as Preset Up and Preset Down for a long button press.

1. Turn the key to ignition but do not start the vehicle.
2. Press and hold the desired steering wheel control button for (10) seconds, or until the L.E.D. flashes rapidly. At this point release the button; the L.E.D. will then go solid.
3. Press and release the **Volume Up** button the number of times corresponding to the new button number selected. Refer to the **Dual Assignment Legend**. The L.E.D. will flash rapidly while the **Volume Up** button is being pressed, and then go back to a solid L.E.D. once released. Proceed to the next step once the **Volume Up** button has been pressed the desired number of times.

**Caution:** If more than (10) seconds elapses between pressing the **Volume Up** button, this procedure will abort, and the L.E.D. will go out.

4. Press the desired button to store it to memory. The L.E.D. will now go out indicating the new information has been stored to memory.

**Note:** These steps must be repeated for each button desired to assign a dual assignment feature to. To reset a button back to its default state, repeat Step 1, then press the **Volume Down** button. The L.E.D. will go out, and the dual assignment feature for that button will be erased.

### Dual assignment legend

- |                   |                |                |                 |
|-------------------|----------------|----------------|-----------------|
| 1. Not allowed    | 6. ATT/Mute    | 11. Play/Enter | 15. Fan-Up *    |
| 2. Not allowed    | 7. Preset-Up   | 12. PTT        | 16. Fan-Down *  |
| 3. Seek-Up/Next   | 8. Preset-Down | 13. On-Hook    | 17. Temp-Up *   |
| 4. Seek-Down/Prev | 9. Power       | 14. Off-Hook   | 18. Temp-Down * |
| 5. Mode/Source    | 10. Band       |                |                 |

\* Not applicable in this application

### Resetting the Axxess interface

1. The **Blue** reset button is located inside the Axxess interface, between the two connectors. The button is accessible outside the Axxess interface, no need to open the Axxess interface.
2. Press and hold the reset button for (2) seconds, then let go to reset the Axxess interface.
3. Refer to the **Programming** section from this point.



**99-3028S**  
INSTALLATION INSTRUCTIONS



If you are having difficulties with the installation of this product, contact our Tech Support line either by phone at **1-800-253-TECH**, or email at **techsupport@metra-autosound.com**. Before doing so, look over the instruction booklet a second time and ensure that the installation was performed exactly as the instruction booklet is stated. Have the vehicle apart and ready to perform troubleshooting steps before contacting Metra/Axxess Tech Support.



**KNOWLEDGE IS POWER**

Enhance your installation and fabrication skills by enrolling in the most recognized and respected mobile electronics school in our industry. Log onto [www.installerinstitute.com](http://www.installerinstitute.com) or call 800-354-6782 for more information and take steps toward a better tomorrow.



**Metra recommends MECP certified technicians**