



#20124

Mid mount Alternator Bracket Kit

Parts List

Alternator

- 1- (20124)-Alt Bracket
- 2- (TP3 2.830) Spacer (between alt bracket & waterpump)
- 1- (TP3 3.250) Spacer (between alternator & alt bracket)
- 1- (S248) 3/8-16 x 1" S.H.C.S. (S.S. Rod to waterpump)
- 1- (RA 1.625) SS Rod
- 2- (S667) 3/8 x 5/8 S.S. Washers (between alt bracket & (TP3 3.250) spacer - non-Edlebrock)

Relocator

- 1- (20141) Relocator
- 1- 3/8-16 x 1" S.H.C.S.
- 1- 5/16-18 x 7/8" S.H.C.S.

Alt Only Kit

- Performance (6310-220) Pulley Kit w/ 314 W.P. Cap 42.5" Serpentine Belt

High Water Flow

- (6370-220) Pulley Kit w/ 314 W.P. Cap 42.5" Serpentine Belt

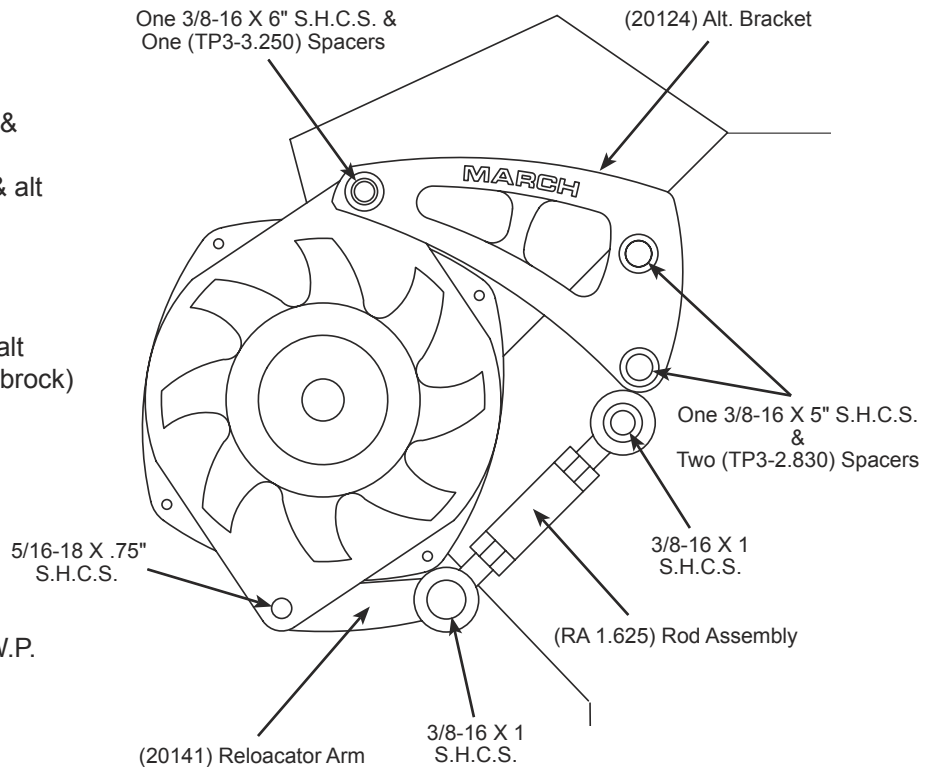

S.H.C.S. = Socket Head Cap Screw
H.H.S. = Hex Head Screw
S.S. = Stainless Steel

Assembly Instructions

1. Bolt (20124) Alternator Bracket & Waterpump to engine block using two 3/8-16 x 5" S.H.C.S. & two (TP3-2.830) Spacers between bracket & waterpump. Do not tighten completely yet.
2. Bolt Alternator to engine head using one 3/8-16 x 6" thru Alternator Bracket & one (TP3-3.250) Spacer between Alternator & engine head. **(Note: if using a polished alternator, check the width of the ear on the alternator. If it is less than 2" wide, Washers (S667) may be used between alternator & spacer or spacer and head to provide correct dimension. See Fig.1)** Completely tighten all screws.
3. Bolt (20141) Relocator Bracket to Alternator using one 5/16-18 x 7/8" S.H.C.S..
4. Bolt (RA 1.625) Stainless Steel Rod Assembly to Relocator Bracket using one 3/8-16 x 1" S.H.C.S.
5. Install belt.
6. Bolt other end of (RA 1.625) Stainless Steel Rod Assembly to waterpump using one 3/8-16 x 1" S.H.C.S.
7. Adjust belt tension using (RA 1.625) Stainless Steel Rod Assembly.

