



151 INDUSTRIAL DRIVE  
ASHLAND, MISSISSIPPI 38603  
<http://www.tciauto.com>

TELEPHONE: 662-224-8972  
FAX LINE: 662-224-8255  
E-MAIL: [tech@tciauto.com](mailto:tech@tciauto.com)

## TCI® 376715

### Holley Carburetor - Throttle Valve Cable Corrector

#### TCI® 376715 Kit Contains:

<u>Qty.</u>	<u>Description</u>
1	Corrector Plate
1	Nut
1	Bolt

Frequently the throttle cable detent is pulled out of adjustment at wide-open throttle. This problem occurs with Holley carburetors in use with most GM transmissions with cables, and most Ford AOD transmissions. This is typically caused by inaccurate geometry of the carburetor linkage plate. In order for the TV to function properly there must be a specific degree of movement of the throttle valve linkage and the carburetor linkage. When either of these two distances is greater than the spec, the TV cable will be pulled out of adjustment. The TCI® 376715 TV cable corrector kit adjusts the geometry of the TV linkage to prevent the TV cable from being pulled out of adjustment at full throttle. This will not fit some early models of Holleys and some versions of the Holley Dominator.

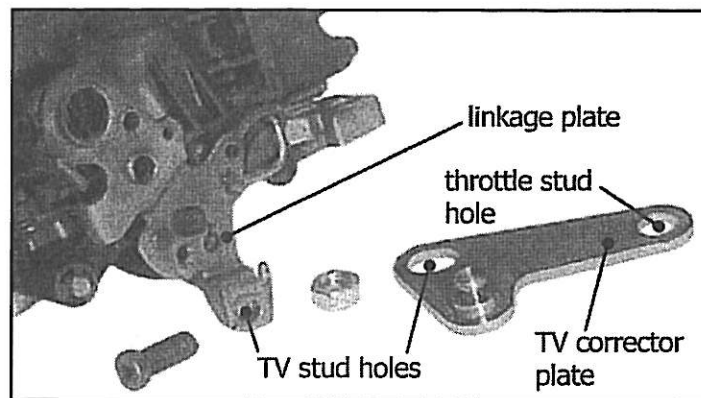

#### Installation Instructions:

1. Disconnect the TV cable and main carburetor linkage cable.
2. Remove the TV stud and main linkage stud from the carburetor.
3. To install the TV corrector plate, face the stud on the corrector plate away from the carburetor. Line up the slotted hole with the TV stud hole on the carburetor linkage plate. Loosely fit the nut and bolt into the holes.
4. Line up the second hole in the corrector plate with the main linkage stud hole in the carburetor plate. Insert the main linkage stud into the hole and secure it with the nut.
5. Tighten up the stud and bolt. Attach the main linkage cable to the stud. The TV cable should be attached to the stud on the corrector plate.

**TRANS  
HELP™**  
662-224-8972