

3000 SERIES STEPGUARD

GRILLE GUARD ASSEMBLY INSTRUCTIONS

PART NO. 3075B & 3075C 02-05 CHEVY TRAILBLAZER 4DR 2/4 WD

Do not attempt to install this product on any vehicle other than the one it is designed for and listed above!

PART LIST

<u>QTY</u>	<u>PART DESCRIPTION</u>	<u>QTY</u>	<u>PART DESCRIPTION</u>
6	3/8 x 1 1/4" HEX BOLT	2	1055A UPPER MOUNTING BRACKET
4	3/8 x 1" HEX BOLT	1	1055D DRIVER SIDE LOWER BRKT
4	3/8 x 1" BUTTON BOLT	1	1055P PASSENGER SIDE LOWER BRKT
6	3/8" FLAT WASHER	4	1/2" HEX NUT
10	3/8" LOCK WASHER	2	5/16 X 3/4" HEX BOLT
10	3/8" HEX NUT	2	5/16" FLAT WASHER
4	1/2 X 1 1/2" HEX BOLT	2	5/16" LOCK WASHER
4	1/2" FLAT WASHER	2	5/16" HEX NUT
4	1/2" LOCK WASHER	1	P200 PLUG KIT

ASSEMBLY INSTRUCTIONS

READ THE ASSEMBLY AND INSTALLATION INSTRUCTIONS COMPLETELY BEFORE YOU BEGIN.

STEP 1. BEGIN THE GRILLE ASSEMBLY BY LAYING THE COMPONENTS OUT ON A PROTECTIVE SURFACE.

STEP 2. INSTALL THE TUBE CONNECTORS FROM THE P200 PLUG KIT INTO THE TOP TUBE.

STEP 3. POSITION THE STEP TUBE, CENTER PLATE AND TOP TUBE BETWEEN THE GRILLE GUARD SIDE PLATES.

STEP 4. ATTACH THE STEP TUBE TO THE SIDE PLATES USING THE 3/8" x 1" BUTTON BOLTS, THE CENTER PLATE USING THE 3/8" x 1" HEX HEAD BOLTS, FLAT AND LOCK WASHERS, AND NUTS, AND TOP TUBE USING THE P200 PLUG KIT HARDWARE.

STEP 5. ALIGN THE GRILLE ASSEMBLY AND TIGHTEN ALL NUTS AND BOLTS.

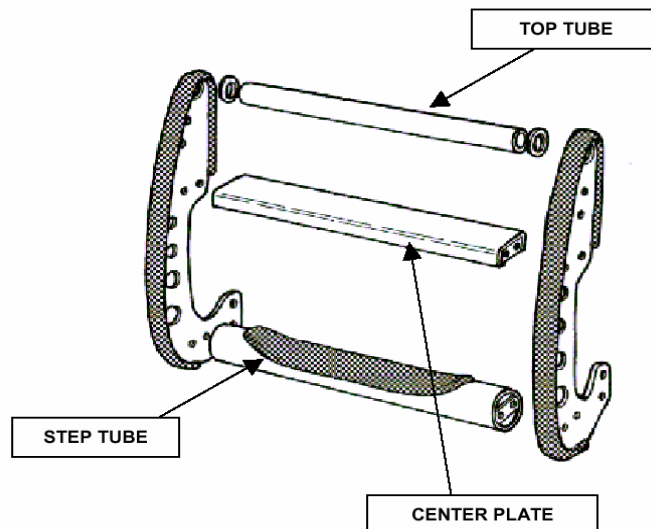

INSTALLATION INSTRUCTIONS

NOTE: THIS INSTALLATION REQUIRES NOTCHING THE LOWER BUMPER FASCIA.

STEP 1. READ THE INSTRUCTIONS COMPLETELY BEFORE BEGINNING THE INSTALLATION.

STEP 2. REMOVE THE TWO 6MM BOLTS SECURING THE PLASTIC BUMPER COVER. THE BOLTS ARE LOCATED BEHIND THE GRILLE ON TOP OF THE BUMPER. THE BOLTS ARE ACCESSIBLE BY CAREFULLY UNSNAPPING THE SIDES AND CENTER, AND THEN PULLING OUTWARD TO REMOVE THE GRILLE.

STEP 3. ATTACH THE 1055A UPPER MOUNTING BRACKETS TO THE BUMPER USING THE FACTORY BOLTS. AND RE-ATTACH THE GRILLE.

STEP 4. LOCATE THE LARGE BRACKETS THAT SECURE BOTTOM OF THE RADIATOR TO THE FRAME. LOCATE THE (4) UNUSED HOLES IN EACH OF THE BRACKETS. (3) OF THE HOLES IN EACH BRACKET WILL BE USED FOR THE LOWER BRACKET MOUNTING POINTS. POSITION THE LOWER BRACKETS BETWEEN THE FLANGES OF THE FRAME BRACKETS, AND LOOSELY ATTACH THE BRACKETS USING THE 3/8 x 1 1/4" BOLTS, WASHERS AND NUTS.

NOTE: ON MODELS EQUIPPED WITH A RADIATOR SKID PLATE. REMOVE THE SKID PLATE, AND DISCARD THE FACTORY MOUNTING BOLTS AND U-NUTS. ATTACH THE MOUNTING BRACKETS AND SKID PLATE TO THE FRAME BRACKETS USING THE 3/8" FASTENERS SUPPLIED.

STEP 5. ATTACH GRILLE GUARD ASSEMBLY TO THE MOUNTING BRACKETS USING 1/2" AND 5/16" FASTENERS. ALIGN THE ASSEMBLY WITH THE FRONT OF THE VEHICLE AND TIGHTEN ALL NUTS AND BOLTS.