



#22020, 22030, 22035, 22050, 22060, 22065

Revised 6-25-07

Chevy Small Block Double Serpentine Kit Long Water Pump

#22021, 22031, 22051, 22061 Deluxe Kits (w/o Alt Fan, W/P Nose Cover, and A/C Nose Cover)

NOTE: Bracket shown in instructions are of our Deluxe Style Kit. Installation is the same for your Ultra Style Brackets

NOTE: Power Steering unit is a 1971 Impala style Keyway pump or 1977 Camaro V-8 Press-fit pump, you should have a 3/8" tap hole at the 6 O'clock both on the front and the rear of the unit. If you have a stud on the rear of the pump remove it.

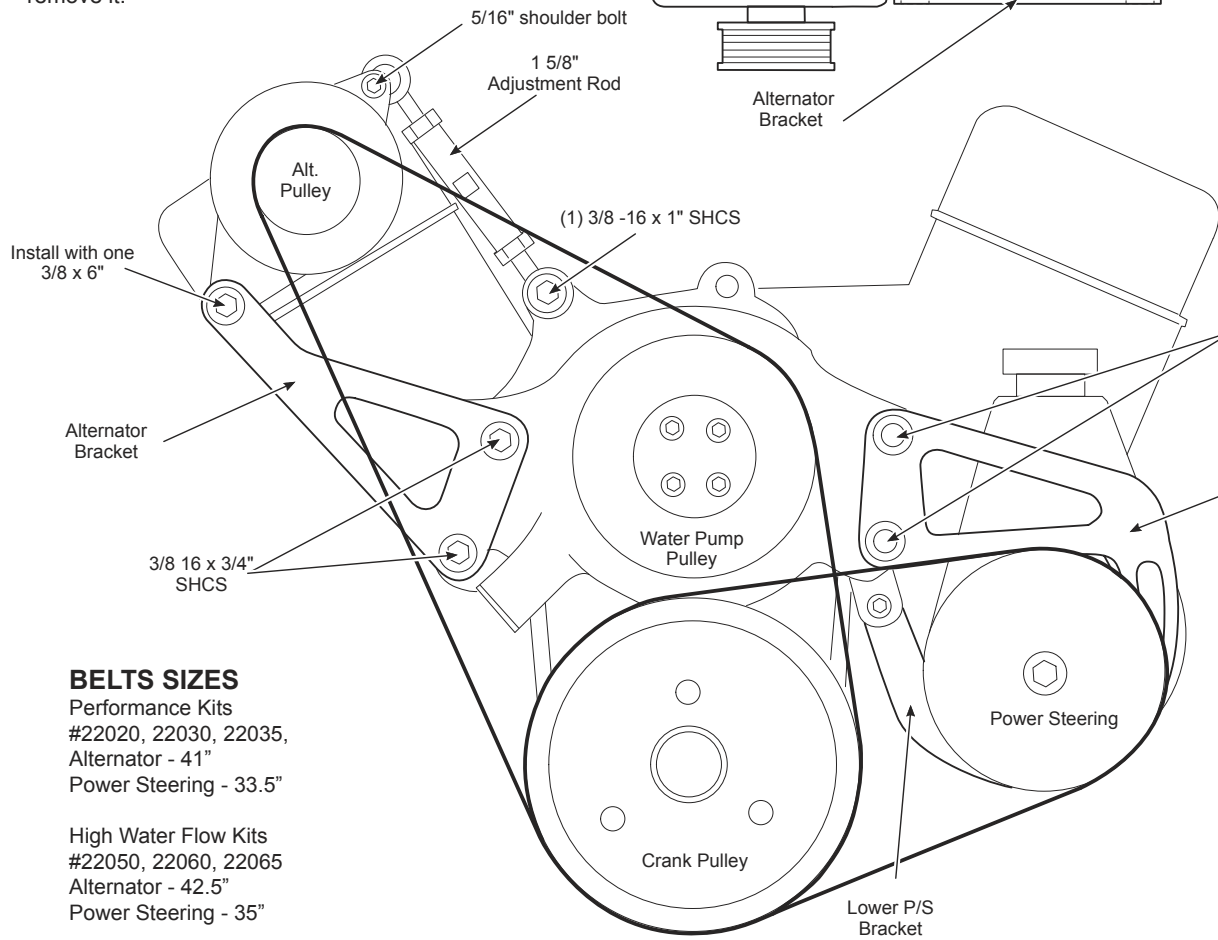
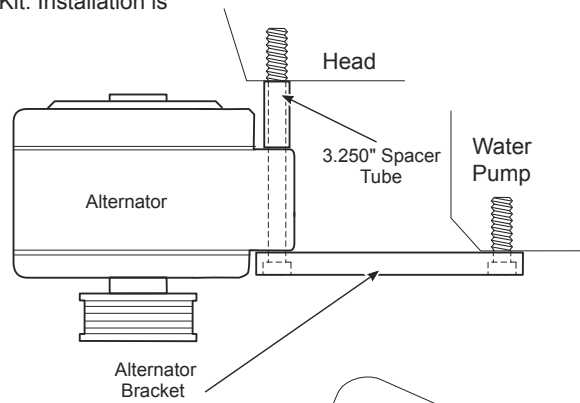

BELTS SIZES

Performance Kits
 #22020, 22030, 22035,
 Alternator - 41"
 Power Steering - 33.5"

High Water Flow Kits
 #22050, 22060, 22065
 Alternator - 42.5"
 Power Steering - 35"

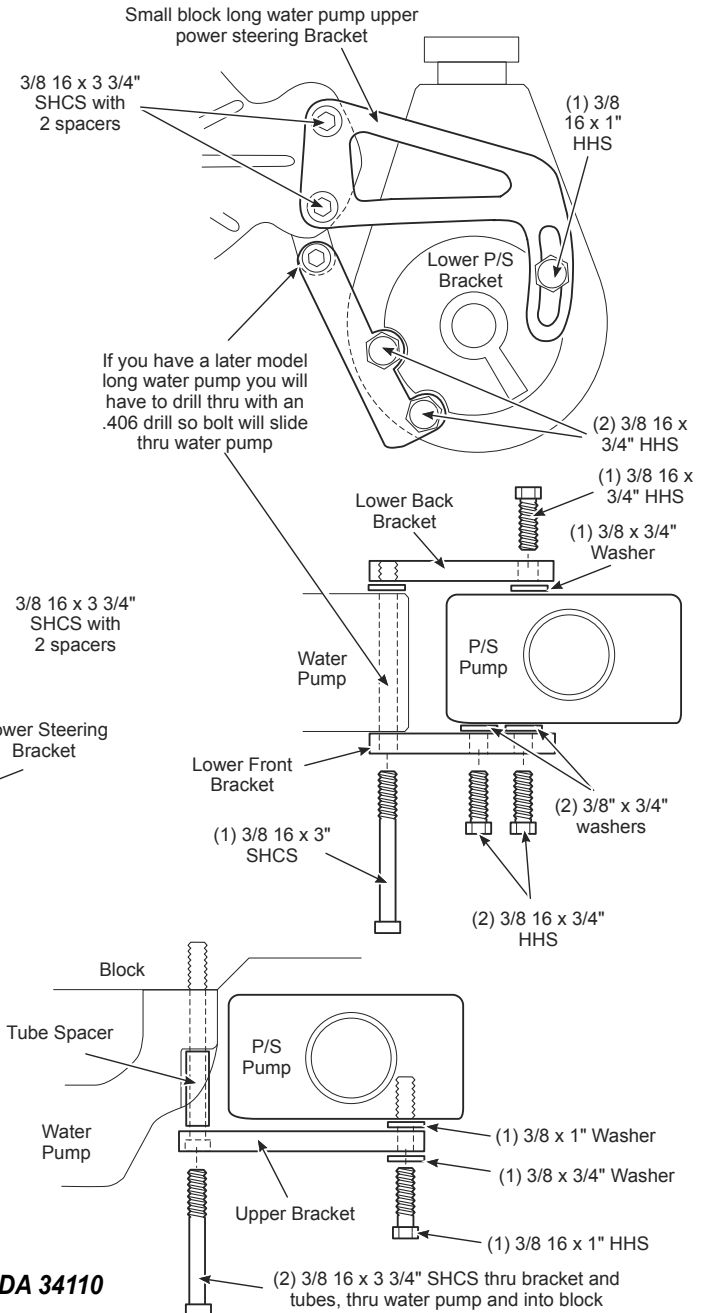

MARCH PERFORMANCE, INC. • 16160 PERFORMANCE WAY • NAPLES, FLORIDA 34110

Technical Support 888-729-9070