



SMOKE, SMOKECAN

WARNING



- THIS CANISTER SHOULD BE REMOVED BEFORE VEHICLE IS IN MOTION!
- Protect from sunlight and DO NOT expose to temperatures exceeding 50°C (122°F)
- DO NOT pierce or burn excess after use!
- Pressurized Container!
- INTENDED FOR OFF ROAD USE ONLY!
- OPERATE IN A WELL VENTILATED AREA!
- DO NOT spray on a naked flame or any incandescent material!
- Keep OUT OF REACH of children!
- DO NOT use while vehicle is in motion!

INSTALLATION

1. Determine the desired location to mount the smoke dressing canister. Keep canister clear of excessive heat and moisture.
2. Mount the canister, so that it is upside down, easy to access for replacement, but not inside vehicle.
3. Determine a mounting location within 12 inches of the canister for the electric solenoid valve.
4. Mount the solenoid valve to a secure location away from excessive heat and moisture.
5. Route copper tube from canister to the solenoid and install all hardware, use thread sealer and tighten. *Caution, do not overtighten, as brass can strip easily.
6. Drill and Tap a 1/2" National Pipe Thread N.P.T hole in the header/exhaust manifold or in the exhaust pipe closest to the motor for best effect.
7. Route pipe from solenoid valve to the header/exhaust manifold and secure with rubber mounting brackets. Make sure to keep it away from excess heat. Make sure to route wiring away from exhaust, motor or moving parts.
8. Install 3/8" N.P.T. adapter to exhaust manifold from exit side of solenoid valve.
9. Run a ignition switch power source to the solenoid valve with a 10 amp in-line fuse.
10. Determine a mounting position for the switch inside the vehicle.
11. Determine the charge your parking brake possesses. It will be either a positive charge when engaged or a negative charge when engaged.
12. Wire relay and switch according to your parking brake charge as shown in the wiring diagram options.

OPERATION

1. Warm up vehicle to normal operating temperature.
2. Put car in park or neutral.
3. Parking brake must be engaged for system to work.
4. Insert AutoLoc™ Smoke Dressing canister into base.
5. Push button. *Note: Smoke will continue to exit exhaust pipe after button is depressed until all smoke dressing is burned off from exhaust pipe inner wall.
6. Turn off vehicle.
7. Remove canister.

**Only Use In A
Controlled Environment!**

Off Road Use Only!

**Do Not Use On Public
Streets Or Highways!**



WARNING: Failure to use AutoLoc™ Dressing Refill Canisters may result in damage and/or clogging to the Smoke Screen Kit and valve.

Additional AutoLoc™ Smoke Dressing canisters are available at
WWW.AUTOLOC.COM

part # SMOKECAN



WIRING DIAGRAM

Option 1

Use When Your Parking Brake Has A Negative Charge When Engaged

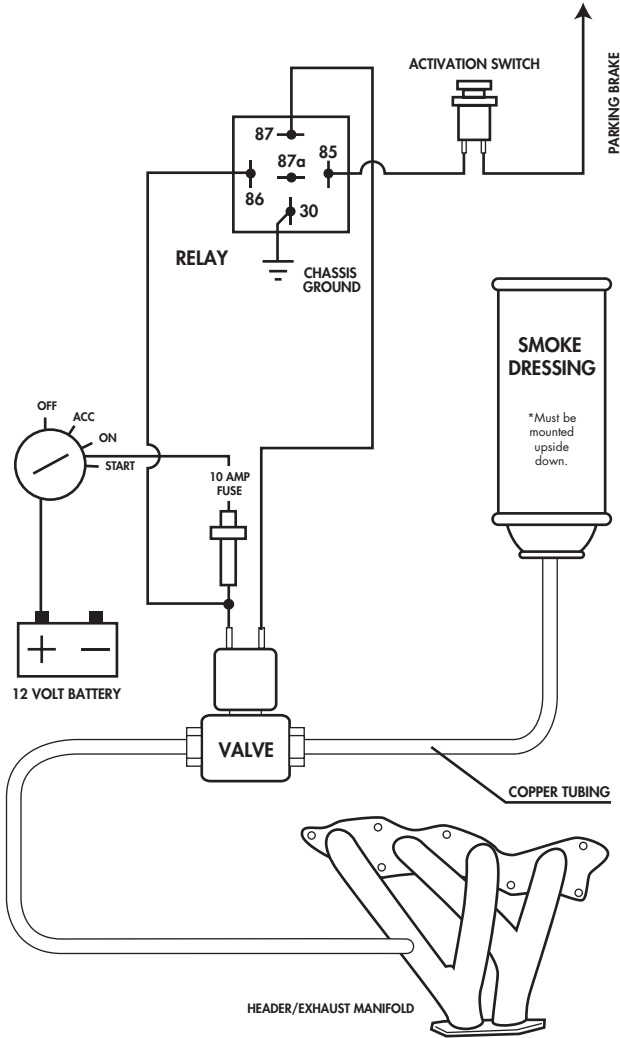

Option 2

Use When Your Parking Brake Has A Positive Charge When Engaged

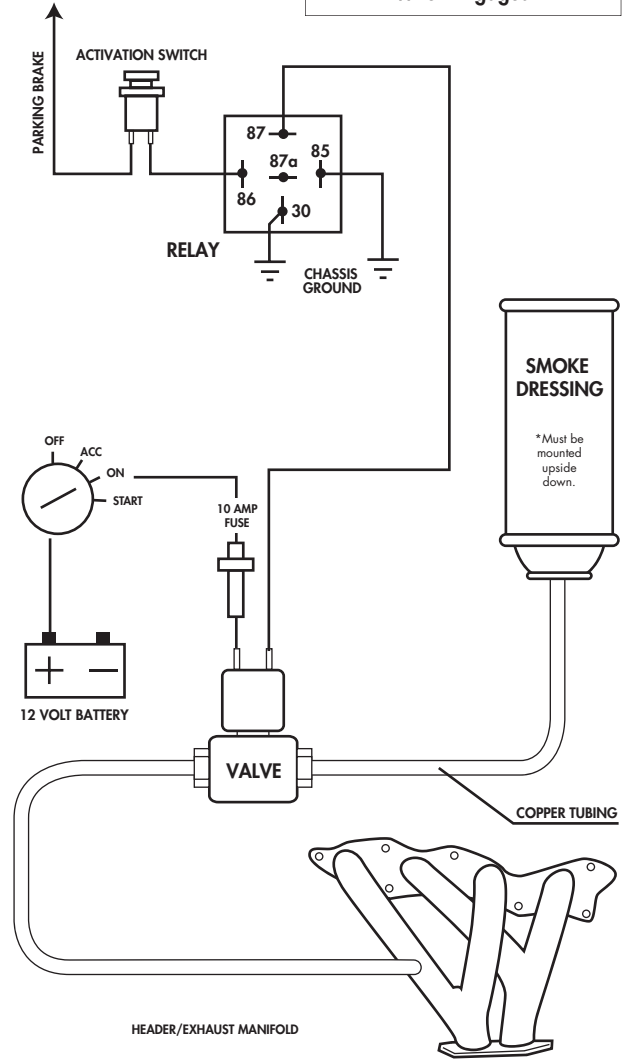

EXAMPLE OF USAGE



1

2

3