



2501 Ludelle Street  
Fort Worth, Texas 76105  
817-244-6212 phone  
817-244-4024 fax  
800-423-9696 Tech  
E-Mail: [painless@painlessperformance.com](mailto:painless@painlessperformance.com)  
Web: [www.painlessperformance.com](http://www.painlessperformance.com)

# 30001

## 12 CIRCUIT ATO FUSE CENTER INSTALLATION INSTRUCTIONS

THE 30001 IS A REPLACEMENT FUSE CENTER FOR INDIVIDUALS WANTING TO UPDATE THEIR CURRENT FUSE BLOCK OR INCREASE THEIR CURRENT ELECTRICAL CAPABILITIES. THE MAIN FUNCTION OF THE BLOCK IS TO PROVIDE FUSED POWER FOR UP TO TWELVE CIRCUITS AND ACT AS A JUNCTION BLOCK FOR THE REMAINING CIRCUITS.

1. FIND A SUITABLE LOCATION UNDER THE DASH (POSSIBLY WHERE THE PREVIOUS FUSE BLOCK WAS LOCATED) AND ATTACH THE FUSE BLOCK MOUNTING BRACKET USING THE HOLES PROVIDED.
2. ATTACH THE WIRE COMING FROM THE HORN SWITCH (IN THE STEERING COLUMN OR FROM EXTERNAL BUTTON) TO THE **HORN SW** TERMINAL. (BLACK WIRE) THIS WIRE, WHEN GROUNDED, ACTIVATES THE HORN RELAY. (18GA)
3. ATTACH THE POWER WIRE FROM THE WINDSHIELD WIPER SWITCH **OR** MOTOR TO THE **WIPER B+** TERMINAL. (BLUE WIRE) (16GA.)
4. ATTACH THE WIRE GOING TO THE IGNITION RESISTOR OR COIL TO THE **COIL/DIST** TERMINAL. (PINK WIRE) (14GA) SEE NOTE "A" BELOW.
5. ATTACH THE WIRE PROVIDING POWER TO THE DOME LIGHT OR TRUNK LIGHT TO THE **DOME LT B+** TERMINAL. (WHITE WIRE) (18GA)
6. ATTACH THE WIRE GOING TO THE ELECTRIC FAN RELAY OR ELECTRIC FAN RELAY SWITCH TO THE **EL FAN B+** TERMINAL. (GRAY W/WHITE STRIPE WIRE) (14GA)
7. ATTACH THE WIRE GOING TO THE A/C-HEATER CONTROL SWITCH TO THE **A/C HEATER B+** TERMINAL. (BLACK W/WHITE STRIPE WIRE) (14GA)

8. ATTACH THE WIRE GOING TO THE IGNITION SWITCHED TERMINAL OF THE ALTERNATOR REGULATOR (INTERNAL OR EXTERNAL) TO THE **ALT IGN B+** TERMINAL. (WHITE WIRE) THIS WIRE TURNS ON THE REGULATOR WHEN THE IGNITION SWITCH IS TURNED ON. (14GA)
9. ATTACH THE WIRE COMING FROM THE IGNITION SWITCH ACCESSORY TERMINAL TO THE **IGN SW ACCY** TERMINAL. (ORANGE WIRE) THIS WIRE SUPPLIES POWER TO THE ACCESSORY SIDE OF THE FUSE BLOCK. (12GA)
10. ATTACH THE POWER WIRE GOING TO THE TURN SIGNAL SWITCH IN THE STEERING COLUMN TO THE **TURN SW B+** TERMINAL. (PURPLE WIRE) (THIS CIRCUIT HAS A FLASHER IN IT) (16GA)
11. ATTACH THE WIRE GOING TO POWER UP THE DASH INSTRUMENTS, WARNING LIGHTS, ETC. TO THE **DASH B+** TERMINAL. (RED W/WHITE STRIPE WIRE) (18GA)
12. ATTACH THE WIRE TO POWER UP THE HEAD LIGHT SWITCH TO THE **LIGHT SW B+** TERMINAL. (RED W/ BLACK STRIPE WIRE) (12GA)
13. ATTACH THE WIRE TO POWER UP THE HAZARD SWITCH TO THE **HAZ SW B+** TERMINAL. (BROWN WIRE) (THIS CIRCUIT HAS A FLASHER IN IT) (16GA)
14. ATTACH THE WIRE FROM THE BATTERY POST ON THE BACK OF THE ALTERNATOR TO THE **ALT BAT POST** TERMINAL. (RED WIRE) (12GA)
15. ATTACH THE WIRE GOING TO POWER UP THE BRAKE LIGHT SWITCH TO THE **STOP SW B+** TERMINAL. (ORANGE WIRE) (14GA)
16. ATTACH THE WIRE THAT PROVIDES POWER TO THE IGNITION SWITCH TO THE **IGN SW B+** TERMINAL. (RED WIRE) (12GA)
17. ATTACH THE WIRE GOING TO THE POSITIVE BATTERY POST OR STARTER SOLENOID TO THE **BAT FEED** TERMINAL. (LARGE RED WIRE) THIS WIRE PROVIDES POWER FOR THE ENTIRE SYSTEM. (10GA)

**NOTE: THE USE OF A 4" PIECE OF (14GA) FUSIBLE LINK AT THE BATTERY OR STARTER END OF THIS CIRCUIT IS STRONGLY RECOMMENDED.**

18. ATTACH THE WIRE FROM THE IGNITION SWITCH IGNITION TERMINAL TO THE **IGN SW COIL** TERMINAL. (PINK WIRE) (14GA) SEE NOTE "A" BELOW.
19. ATTACH THE WIRE GOING TO THE HORN ITSELF TO THE **TO HORN** TERMINAL. (GREEN WIRE) (14GA)
20. ATTACH THE WIRE GOING TO THE RADIO FOR POWER TO THE **RADIO B+** TERMINAL.

**NOTE A:** THE WIRE NORMALLY GOING FROM THE IGNITION SWITCH IGNITION TERMINAL TO THE COIL IGNITION RESISTOR HAS BEEN CUT IN HALF TO GO THROUGH THE FUSE IN THE FUSE BLOCK. THIS IS DONE FOR TWO REASONS, IT PROVIDES A FUSED IGNITION CIRCUIT FOR ELECTRONIC FUEL INJECTION SYSTEMS AND A THEFT DETERRENT. BY REMOVING THE FUSE YOU WILL DISABLE THE IGNITION CIRCUIT.

**NOTE B:** THE WIRE COLOR CODING NOTED IN EACH STEP IS THE COLOR OF WIRES AT THE FUSE BLOCK. COLOR CODING OF YOUR VEHICLES WIRES MAY NOT BE THE SAME.

**B+** MEANS BATTERY POWER

**(14GA)** THESE SYMBOLS, AFTER EACH INDIVIDUAL INSTRUCTION, INDICATE THE RECOMMENDED WIRE SIZE ( MAY NOT BE ORIGINAL SIZE) OF WIRE TO USE BETWEEN THE FUSE BLOCK & THE COMPONENT.

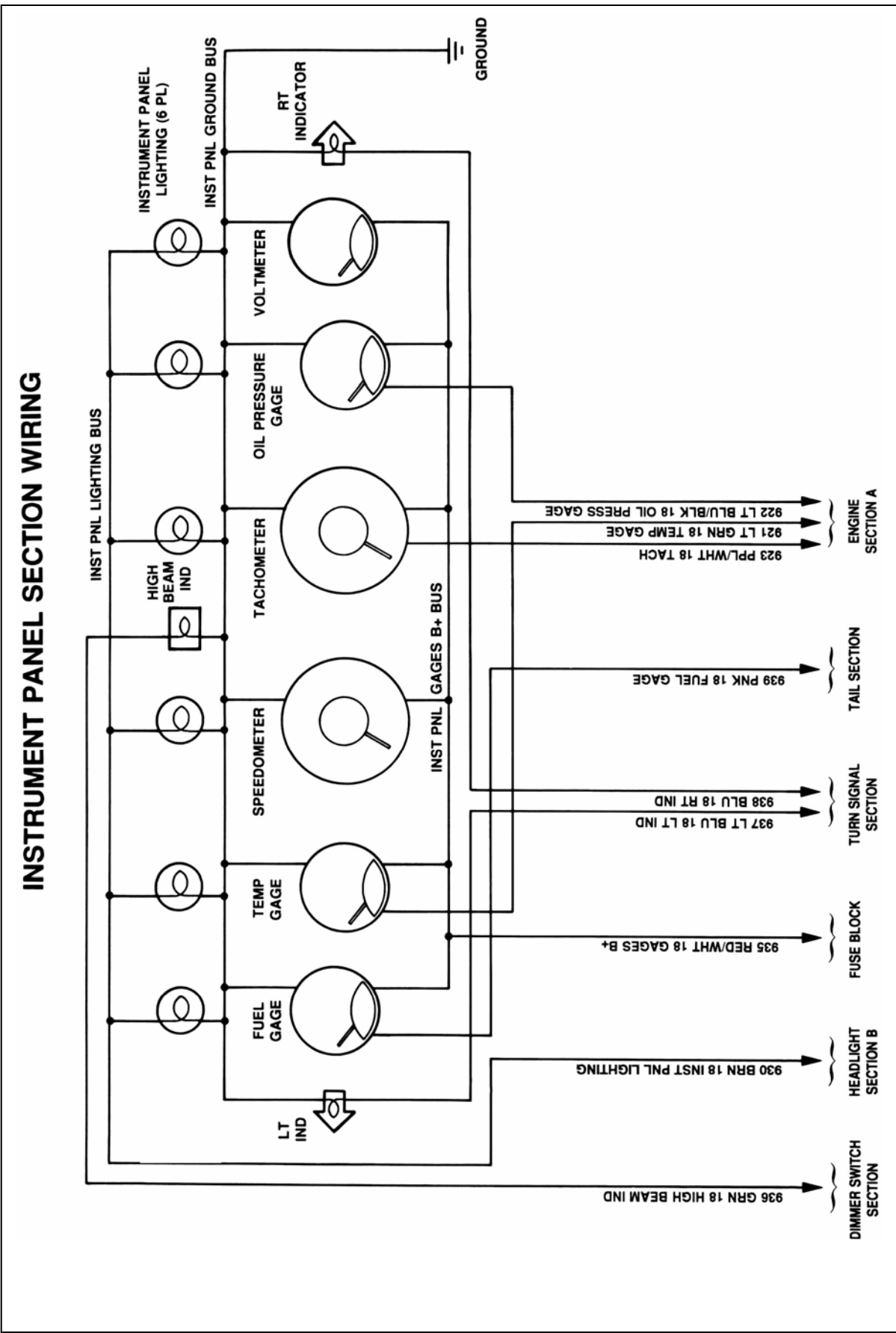

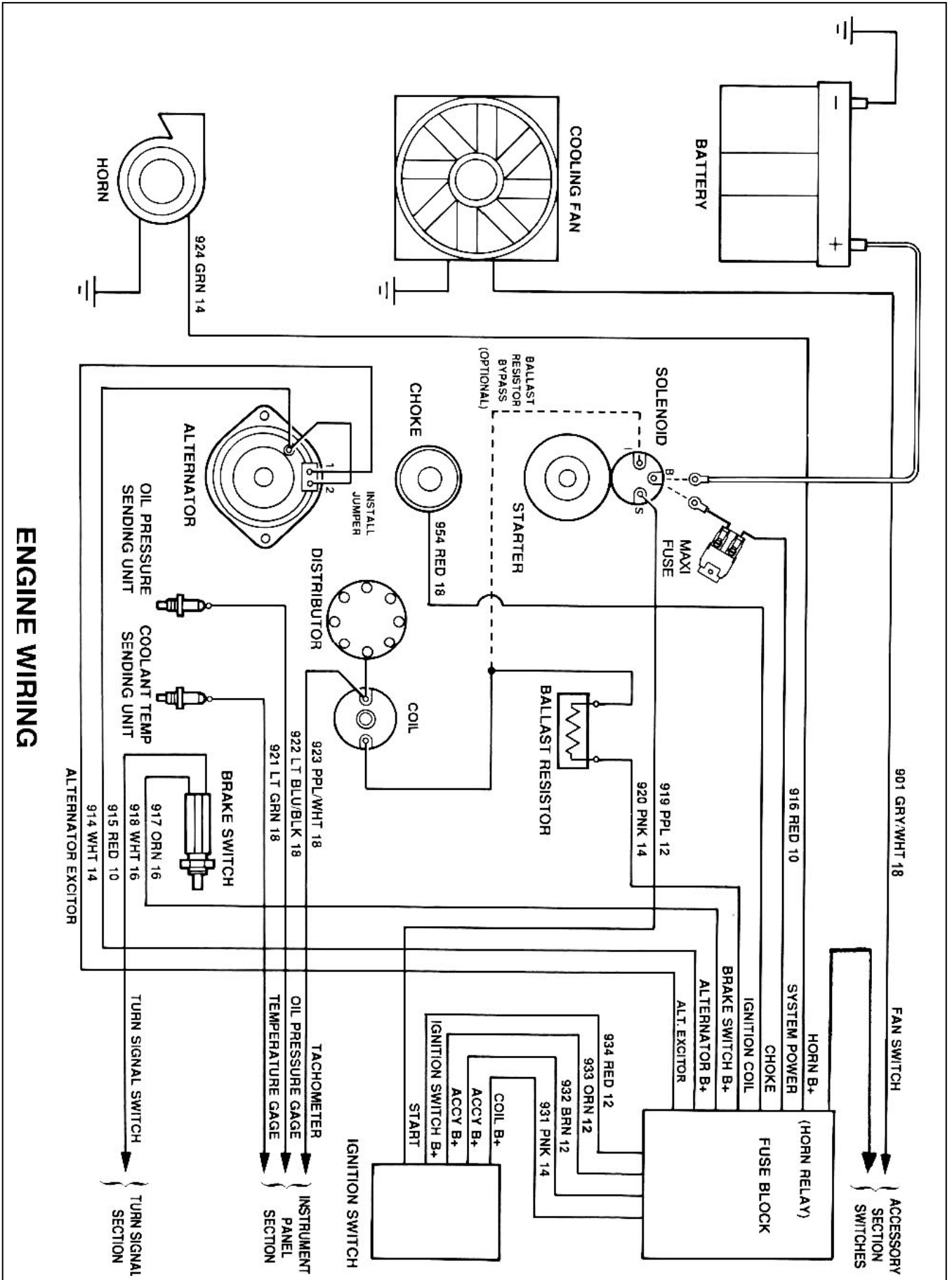

## **Painless Performance Limited Warranty and Return Policy**

Chassis harnesses and fuel injection harnesses are covered under a lifetime warranty. All other products manufactured and/or sold by Painless Performance are warranted to the original purchaser to be free from defects in material and workmanship under normal use. Painless Performance will repair or replace defective products without charge during the first 12 months from the purchase date. No products will be considered for warranty without a copy of the purchase receipt showing the sellers name, address and date of purchase. You must return the product to the dealer you purchased it from to initiate warranty procedures.