



Steering, Brake & Suspension Specialists

#CP30102 - Installation Instructions for 1955-57 Chevrolet Fullsize Car 2" Drop Spindles

Parts List:

2 ea	1955-1957 Drop Spindle	4 ea	1/2 Lock Washers
4 ea	Steering Arm Bolt	4 ea	1/2 Flat Washers
4 ea	Steering Arm Nut	6 ea	Cotter Pins
4 ea	1/2-13 x 1-1/2 Caliper Bracket Bolts		

Recommendations:

CPP recommends using new ball joints, tie rod ends, and wheel bearings while installing this kit. CPP recommends using the CPP 13" brake kit (#5577WBK-P13) with this spindle.

Notes:

This spindle will not work with drum brakes.

Instructions:

1. Remove the steering arm from the spindle.
2. Disconnect the brake hose from the brake line.
3. Remove the upper and lower ball joints from the spindle.
4. Remove the old spindles.
5. Install the new drop spindles onto the upper and lower ball joints.
6. Install the steering arms onto the new spindles.

7. Install the caliper brackets. The brackets will mount to the inboard side of the spindle.
8. Pack the wheel bearings with grease. Install the inner bearings and the grease seal. Install the rotor/hub assembly. Install the outer wheel bearing, washer and spindle nut. Adjust the wheel bearings as follows:
 - a. Tighten the nut only slightly (no more than 12lb/ft.) spin the rotor in a forward direction to ensure the bearings are fully seated.
 - b. Check that the spindle nut is still tight. If not repeat step a.
 - c. Loosen the spindle nut until it is just loose.
 - d. Hand tighten the spindle nut and install the cotter pin. Do not use a wrench! If necessary loosen the nut too the first position the cotter pin can be installed into.
9. Install the caliper assemblies. The bleed screws will be towards the top.
10. Connect the brake hose to the calipers and the frame. Bleed the brakes. Check for leaks.
11. Check that the rotor can turn freely and that the brakes do not drag.
12. Have the car professionally aligned.

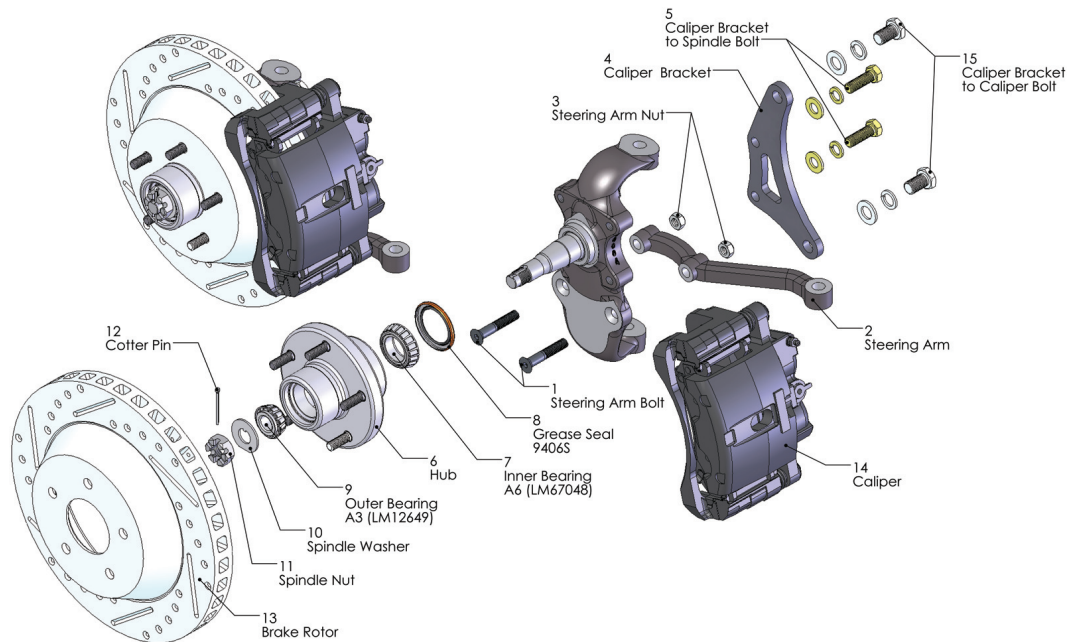

For technical help call Classic Performance Products Monday thru Friday 8:30am to 5:00pm at (714) 522-2000

Classic Performance Products, Inc. 714.522.2000 | fax 714.522.2500

175 E. Freedom Avenue | Anaheim, CA 92801 | www.classicperform.com