

#6372MP-SM Sheet Metal Engine Mount Instructions

1963-72 Small Block and LS1 V8 Engine Mount

Notes:

The original rubber engine mounts will need to be changed to the 1959-1970 passenger car. This bracket will mount a LS1 engine when used with CPP engine mount adapters.

Instructions:

1. Remove the original engine mounting brackets, and rubber engine mounts.
2. Install the new rubber engine mounts on to the engine.
3. Install the new engine mounting brackets.

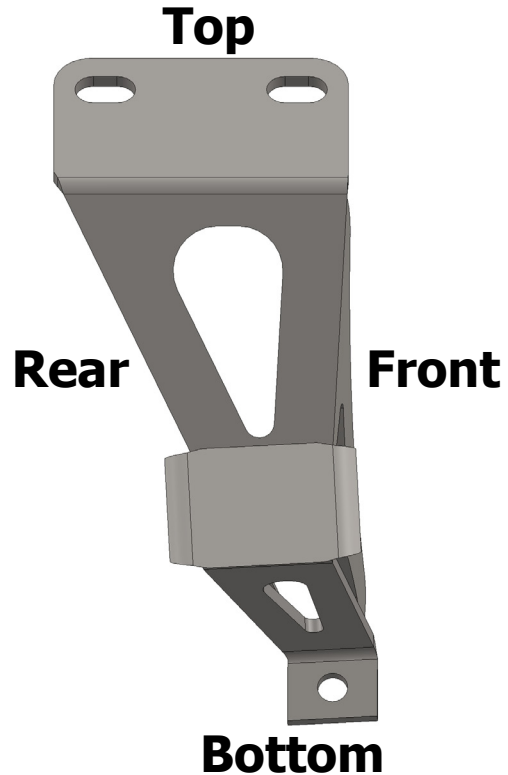

GENERAL TORQUE SPECIFICATIONS:					
1/4"	grade 5	10lb/ft	1/4"	grade 8	14lb/ft
5/16"	grade 5	19lb/ft	5/16"	grade 8	29lb/ft
3/8"	grade 5	33lb/ft	3/8"	grade 8	47lb/ft
7/16"	grade 5	54lb/ft	7/16"	grade 8	78lb/ft
1/2"	grade 5	78lb/ft	1/2"	grade 8	119lb/ft
9/16"	grade 5	114lb/ft	9/16"	grade 8	169lb/ft
5/8"	grade 5	154lb/ft	5/8"	grade 8	230lb/ft

NOTE: With 18" and larger wheels we recommend 1/2" wheel studs. The larger the wheel diameter, the greater the force is on the wheel studs. Please inquire about replacement wheel stud kits available from CPP.

© Classic Performance Products, Inc. 2013
All rights reserved. This document may not be reproduced without prior written permission of CPP.

For technical help call Classic Performance Products Monday thru Friday 8:30am to 5:00pm at (714) 522-2000.

Classic Performance Products, Inc. 714.522.2000 | fax 714.522.2500
378 E. Orangethorpe Ave. | Placentia, CA 92870 | www.classicperform.com