



QUALITY... PLAIN & SIMPLE®

Ford C-4 Hi-Tech Kickdown Kit
Part# KD-20C4HT

Ford C-4 Hi-Tech Kickdown Kit Installation Instructions

Part# KD-20C4HT

Building American Quality... With A Lifetime Warranty!

10924 Murdock Dr. • Knoxville, TN 37932

TOLL FREE 1-877-469-7440 • (865) 966-2269 • FAX (865) 671-1999 • tech@lokar.com • www.lokar.com

General Installation Notes:

Please read instructions completely before beginning installation. If you have any questions please call.

Do not attempt to install or adjust Throttle Cable or Kickdown kit while engine is running. Be sure engine, body and frame are grounded properly.

We recommend using an anti-seize lubricant on all aluminum threads before installation. Do not over tighten while fitting cables.

Cut housing by using diagonal cutters, Lineman pliers or taping the housing and using a fine-toothed hacksaw. Klein diagonal cutters, part no. D2000-28 (available at Grainger's, part no. 4A838) work best.

Ford C-4 Hi-Tech Kickdown Kit Installation

Step 1: Install kickdown lever on trans with cable hole to trans side as shown in **Fig. 1**.

Step 2: Mount cable bracket to trans as shown in **Fig. 1**.

Step 3: Mount adjuster bracket to spring return bracket as illustrated in **Fig. 2**.

Remove inner wire from outer housing.

Step 4: Route braided line up to adjuster. Slide the ferrule back onto the housing and measure between both fittings. Add one inch (1") and cut outer housing as described in General Installation Notes. Once housing is cut, slide the ferrule to the end of the housing and reinstall into adjuster fitting. Be sure to mock up the housing as it will be routed in the final installation.

Step 5: Install Hex Carb fitting with plastic Lokar Cable Slide Fitting and install tear drop for springs. Hook spring to Tear Drop and tighten hex carb fitting.

Step 6: Reinstall inner wire in outer housing and run inner wire through Lokar cable slide fitting.

Step 7: Slide kickdown cable stop over end of wire like **Fig. 2**.

Step 8: Make final adjustments by holding throttle to wide open and pulling the kickdown inner cable as tight as possible. Slide cable stop up against Lokar Cable Slide Fitting and tighten allen set screw. When the kickdown is properly adjusted you should be able to open the throttle to wide open position and there should be no slack in the kickdown cable.

Fig. 1

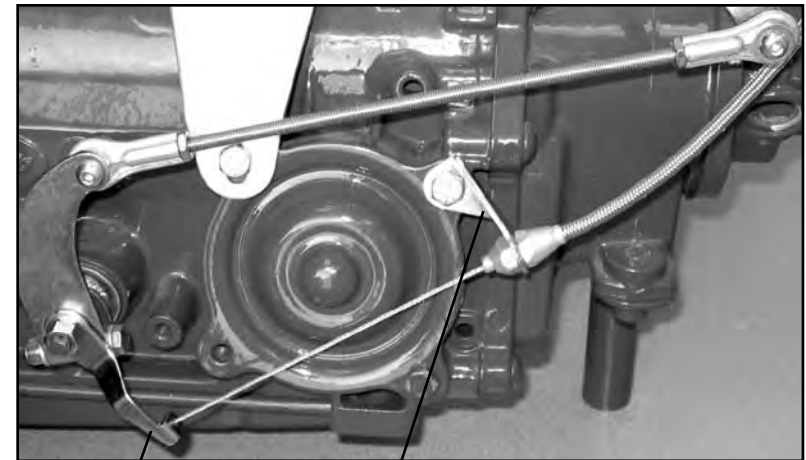

Kickdown Lever

Trans Cable Bracket

Fig. 2

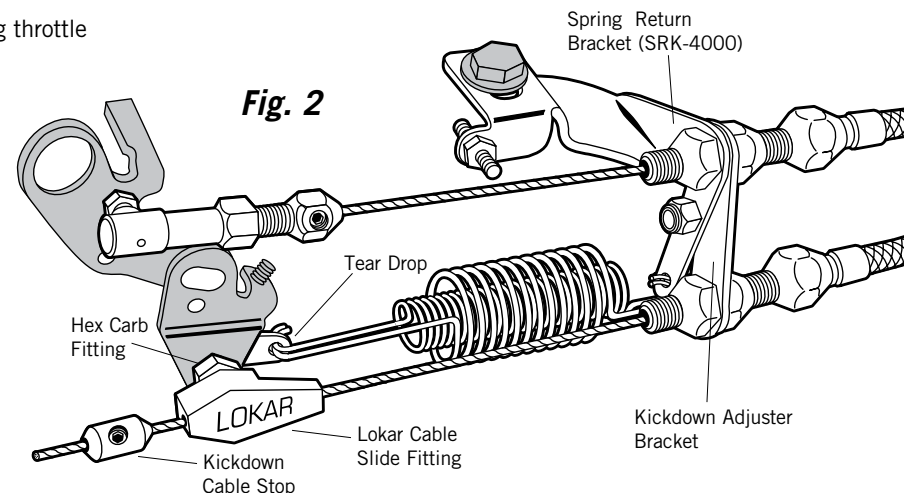

Spring Return Bracket (SRK-4000)

Hex Carb Fitting

Tear Drop

Kickdown Cable Stop

Lokar Cable Slide Fitting

Kickdown Adjuster Bracket