

This kit fits '67-'81 Camaro V8, '75 Buick Apollo V8, '75-'79 Buick Skylark V8, '67-'81 Firebird V8, '62-'79 Nova/Chevy II V8, '73-'79 Omega V8, '72-'79 Phoenix & Ventura V8, all with standard headers and with 3" collectors at the headers.

**Note:** the catalytic converters are not supplied with this exhaust system. This system is not legal for on-road use on vehicles that originally were equipped with a catalytic converter.

**Note:** the headers are not included in this kit!!

**Hardware kit:**

- |                                  |   |
|----------------------------------|---|
| 4) st4 hangers                   | 2) left & right collector pipes         |
| 4) snapper grommets              | 2) #s43122 single offset turbo mufflers |
| 4) 5/16" x 1" lag screws         | 2) left & right front extension pipes   |
| 8) 2-1/2" clamps                 | 1) left tail pipe                       |
| 2) f33 flanges                   | 1) right tail pipe                      |
| 6) 3/8" nuts                     |   |
| 6) 3/8" lockwashers              |   |
| 6) 3/8" x 1-1/4" bolts           |   |
| 2) #mp48005 3" collector gaskets |   |

Hanger consists of a metal strap, grommets, hardware, and clamp (see illustration).

**Installation instructions for kit # 680101, #8158670m:**

Note: do not tighten any clamps or nuts until the last step!!

- 1) Remove the old exhaust system after the headers. Remove the old hangers and brackets.
- 2) Install the left and right collector pipes using the mp48005 gaskets and f33 flanges. Tighten only enough to hold in place, using the 3/8" x 1-1/4" bolts and nuts. **Note:** for vehicles requiring catalytic converters to meet epa guidelines, catalytic converter #73-7774 or equivalent should be installed on the header collector pipes after the header collectors on the collector pipes.



- 3) Install the left and right front extension pipes to the collector pipes using 2-1/2" clamps. Be sure to leave adequate clearance between the floor boards and the drive shaft. **Note:** the extension pipes may be shortened to fit various header designs or different length mufflers.
- 4) Install the mufflers onto the front extension pipes using 2-1/2" clamps. Rotate the front extension pipes to clear the driveshaft, and frame, and general clearance.



5) Mount the hanger brackets to the existing holes in the frame behind the rear axle using the lag screws and the snapper grommet (see drawing). The hangers should be installed to the tail pipes at where the tail pipes cross under the frame. Two additional hangers have been included to use at your preferred location.

6) Install the left and right tail pipes to the mufflers using 2-1/2" clamps. Use a 2-1/2" clamp to connect the pipes and a hanger.



7) Make sure that all the parts of the system are clear of frame members, all hoses, suspension, and brake and fuel lines. Starting at the collector pipes, tighten all connections and nuts. Make sure all parts are clear and will not leak or rattle. After several days of driving retighten all bolts.



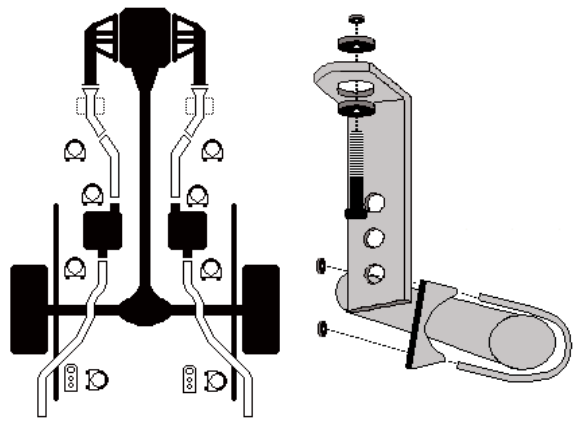
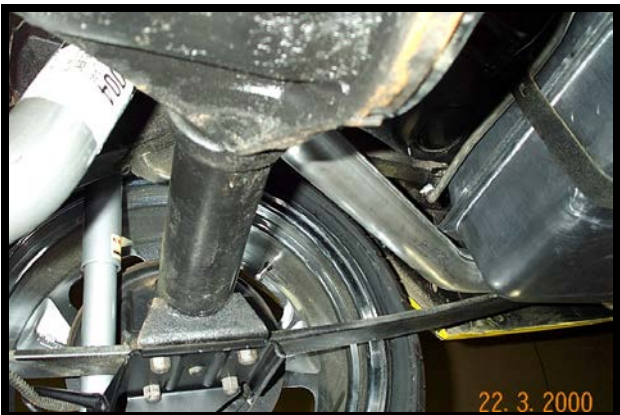



---

## 2-1/2" Aluminized Header Dual Exhaust Kit

### SUM-680101

---

**DANGER WARNING:** SHOULD THE PURCHASER DECIDE TO INSTALL THIS, OR ANY OTHER EXHAUST PRODUCT AT HOME, BE WARNED THAT PLEASURE CAR OR LIGHT DUTY TRUCK/VAN "BUMPER JACKS" ARE INTENDED FOR EMERGENCY USE ONLY. THE USE OF FRAME CONTACT JACK STANDS IN CONJUNCTION WITH A FLOOR JACK AS MAIN SUPPORT IS HIGHLY RECOMMENDED TO MINIMIZE ACCIDENTAL DROPPING OF A VEHICLE WHILE THE INSTALLATION PROCEEDS.

**Limitation of liability--Disclaimers:** The regulation of emissions production, noise levels and safety standards is undertaken by the federal government, each of the fifty state legislatures, and by many local municipalities, towns and counties.

The manufacturer makes no warranties of merchantability, of fitness for a particular purpose, or that its products are approved for general use, or that its products comply with laws, regulations or ordinances in the states where they may be sold to the ultimate purchaser, the consumer.

The entire risk as to the conformity of this product in any such state and as to repair, should the product prove to be defective or non-conforming, is on the retail purchaser, the buyer, the ultimate consumer of such product and it is not upon the seller, distributor, or manufacturer.

In this connection, retail purchaser, the buyer, the ultimate consumer assumes the burden of the entire cost of any and all necessary service, alterations, and or repair.

The foregoing statement limits the liability of the manufacturer.

## Limited One-Year Warranty

This Limited One-Year Warranty is given to the original purchaser (the "Buyer") of this new Summit or Summit Performance Branded Product. Summit Racing Equipment warrants that the product will be free from defects in workmanship and materials under normal use and service for one year from the date of purchase.

**Your responsibilities:**

Keep a sales receipt, canceled check, or payment record to verify your purchase date. Operate and maintain the product in accordance with the specifications provided to you with the product. Arrange for or pay items and costs that are not covered by this Limited Warranty.

**What is not covered:**

1. Damages caused by shipping, product misuse, misapplication, improper installation or maintenance, or damages resulting from accidents, contact with on-road or off-road hazards, or racing engine use.
2. Labor costs to remove and install the products or component parts.
3. The costs of shipping the product to and from Summit Racing Equipment.

**Claims Procedure:**

The duration of this warranty is limited to claims made in writing to Summit Racing Equipment within one year after the Purchase Date. The Buyer should call the telephone number below to report a possible warranty claim. The Buyer must also allow Summit Racing Equipment to inspect the product, and the Buyer must reasonably cooperate with Summit Racing Equipment with respect to verifying the warranty claim of the Buyer. In the event that a warranted defect is discovered, Summit Racing Equipment will repair or replace the product, or return the purchase price to the Buyer, at the option of Summit Racing Equipment.

All shipping costs are paid by the Buyer. Merchandise returned to Summit Racing Equipment without prior authorization will not be accepted.

This warranty extends only to the Buyer and is not transferable.

Implied warranties applicable to this transaction extend only to one year. Some states do not allow limitations on how long an implied warranty lasts, so the above limitation may not apply to you.

Summit Racing Equipment shall not be responsible for any incidental or consequential damages of the Buyer. Some states do not allow the exclusion or limitation of incidental or consequential damages, so the above limitation may not apply to you.

This warranty gives you very specific legal rights, and you may also have other rights which vary from state to state.

**Questions? Call our Tech Line 1-800-230-3030**

**BUILD SHEET FOR: 2-1/2" HEADER DUAL KITS**

**PART #'S: 8158670m, 680101**

- \_\_\_\_\_ 2) left & right collector pipes
- \_\_\_\_\_ 2) #s43122 single offset turbo mufflers
- \_\_\_\_\_ 2) left & right front extension pipes
- \_\_\_\_\_ 1) left tail pipe
- \_\_\_\_\_ 1) right tail pipe
- \_\_\_\_\_ 1) Hardware kit

INSPECTED BY: \_\_\_\_\_

DATE: \_\_\_\_\_

INSPECTED BY: \_\_\_\_\_

DATE: \_\_\_\_\_

**BUILD SHEET FOR: 2-1/2" HEADER DUAL KITS**

**PART #'S: 8158670m, 680101**

- \_\_\_\_\_ 2) left & right collector pipes
- \_\_\_\_\_ 2) # s43122 single offset turbo mufflers
- \_\_\_\_\_ 2) left & right front extension pipes
- \_\_\_\_\_ 1) left tail pipe
- \_\_\_\_\_ 1) right tail pipe
- \_\_\_\_\_ 1) Hardware kit

INSPECTED BY: \_\_\_\_\_

DATE: \_\_\_\_\_

INSPECTED BY: \_\_\_\_\_

DATE: \_\_\_\_\_