

P/N 60502 & 60505 1994/1995 GM LT1 FUEL INJECTION WIRE HARNESS INSTALLATION INSTRUCTIONS

Manual P/N 90517
Copyright © May 2002

PAINLESS PERFORMANCE PRODUCTS
2501 Ludelle Street - Fort Worth, Texas 76105-1036 - (817) 244-6898
E-Mail: tech@painlessperformance.com Web: painless@painlessperformance.com

We have attempted to provide you with as accurate instructions as possible, and are always concerned about corrections or improvements that can be made. If you have found any errors or omissions, or if you simply have comments or suggestions concerning these instructions, please write us at the address on the cover and let us know about them. Or, better yet, send us a fax at (817) 244-4024 or e-mail us at painless@painlessperformance.com. We sincerely appreciate your business.

Perfect Performance Products, LLC shall in no event be liable in contract or tort (including negligence) for special, indirect, incidental, or consequential damages, such as but not limited to, loss of property damage, or any other damages, costs or expenses which might be claimed as the result of the use or failure of the goods sold hereby, except only the cost of repair or replacement.

P/N 90517 Painless Wiring Manual

July, 2014

Copyright © 1994 by Perfect Performance Products, LLC

TABLE OF CONTENTS

1.0	INTRODUCTION.....	ii
2.0	ABOUT THESE INSTRUCTIONS.....	ii
3.0	TOOLS NEEDED.....	1
4.0	PRE-INSTALLATION AND HARNESS ROUTING GUIDELINES.....	1
4.1	TRANSMISSION FUNCTION.....	1
4.2	GET TO KNOW THE ENGINE THAT YOU ARE USING.....	2
5.0	GENERAL INSTALLATION INSTRUCTIONS.....	3
5.1	GROUNDING THE VEHICLE.....	3
5.2	ROUGH INSTALLATION.....	4
5.3	HARNESS ATTACHMENT.....	4
5.4	TERMINAL INSTALLATION INSTRUCTIONS.....	4
6.0	GM 94 & 95 LT1 SYSTEM WIRE HARNESS INSTALLATION.....	5
6.1	CONTENTS OF THE 60502 OR 60505 WIRE HARNESS KIT.....	5
6.2	SPECIFIC CIRCUIT CONNECTIONS.....	5
6.3	ENGINE GROUP INSTALLATION.....	9
6.4	TAIL SECTION INSTALLATION.....	13
7.0	TROUBLE-SHOOTING INSTRUCTIONS.....	13
7.1	THE "CHECK ENGINE" LIGHT.....	14
7.2	RETRIEVING TROUBLE CODES FROM THE COMPUTER.....	14
7.3	WHEN TO CALL "PAINLESS WIRING" TECH LINE.....	16

LIST OF FIGURES

Figure 6.1	Diagnostic Link Connector (DLC) & Check Engine Light	5
Figure 6.2	Brake Switch Connection	6
Figure 6.3	Brake Switch Relay.....	7
Figure 6.4	Gear Indicator Switch	7
Figure 6.5	Air Pump Relay Connector	8
Figure 6.6	Canister Purge Solenoid	8
Figure 6.7	Air Pump Connection	9
Figure 6.9	EGR Solenoid	10
Figure 6.10	Knock Sensor	10
Figure 6.11	Oxygen Sensor	11
Figure 6.12	MAP Sensor	11
Figure 6.13	Injectors 1, 3, 5, 7.....	11
Figure 6.14	Injectors 2, 4, 6, 8	11
Figure 6.15	TPS Sensor	11
Figure 6.16	IAC.....	11
Figure 6.17	MAF Sensor	12
Figure 6.18	Distributor Connection.....	12
Figure 6.19	Ignition Module.....	12
Figure 6.20	Coil.....	12
Figure 6.21	ECT Sensor.....	12
Figure 6.22	IAT Sensor.....	12
Figure 6.23	VSS.....	13
Figure 6.24	Transmission Connection	13
Figure 7.1	Fuse Identification.....	14

LIST OF TABLES

Table 4.1	Compatible Parts.....	3
Table 6.1	Dash Section Connections.....	8
Table 6.2	Engine Section Connections.....	10
Table 6.3	Tail Section Connections.....	13
Table 7.1	Diagnostic Trouble Codes.....	14 & 15

1.0 INTRODUCTION

You have purchased what we at Painless Performance Products believe to be the most up-to-date and easiest-to-install automotive fuel injection harness on the market. It is designed for easy installation, even if you have no electrical experience.

This harness is designed to be a complete wiring system for the fuel injection system on General Motors 1994 and newer LT1 injected engines and to control the 4L60E transmission. This includes all wiring that is needed by the computer to run and control the injection system and transmission. A module has been included to bypass the vehicle anti theft system (VATS) incorporated in the computer. When using this harness on a '96 or '97 engine you must replace the coil, coil output wire and knock sensor with the parts from a '92 - '95 engine.

NOTE: The use of a 40 pulse Vehicle Speed Sensor, such as the one that comes standard in the 4L60E transmission, is required when using a 1994 or newer computer for operation of emission devices. The use of any other style transmission, such as a 350 or 400 Turbo, which cannot operate a 40-pulse sensor, will require the use of an earlier style computer. The use of a 4L60E will also require the use of an electronic speedometer because of the absence of a cable drive in the transmission.

Usually, the computer, relays and fuse block can easily be mounted under the dash. Most of the wiring in the harness has been pre-terminated to the proper connector and all wire has been GM color-coded. All wiring is TXL, 600 volt, and 125 degree centigrade with cross-link insulation.

This fuel injection system harness have been divided into three major groups:

ENGINE GROUP	Includes wiring for the fuel injectors, distributor, and sensors.
DASH GROUP	Includes ignition feed wires, assembly line diagnostic link (DLC) connector, check engine light, computer wiring and connectors, brake switch wiring, gear shift indicator wiring, tachometer wiring, air pump, canister purge, VATS and fuse block.
TAIL GROUP	Include VSS wiring, transmission wiring (if applicable) and power wire for fuel pump.

2.0 ABOUT THESE INSTRUCTIONS

These instructions provide information for the installation of the 60502 LT1 (94 & 95) Fuel Injection Harness Kit. The contents of these instructions are divided into major **Sections**, as follows:

1.0	INTRODUCTION
2.0	ABOUT THESE INSTRUCTIONS
3.0	TOOLS NEEDED
4.0	PRE-INSTALLATION AND HARNESS ROUTING GUIDELINES
5.0	GENERAL INSTALLATION INSTRUCTIONS
6.0	60502 LT1 (94 & 95) FUEL INJECTION HARNESS KIT
8.0	TROUBLE-SHOOTING INSTRUCTIONS AND TROUBLE CODES

Sections are further divided into **Paragraphs** and **Steps**. Throughout, the **Figure** numbers refer to illustration and the **Table** numbers refer to information in table form. These are located in or near the sections or paragraphs to which they correspond. Always pay careful attention to any notes or any text labeled **CAUTION**.

3.0 TOOLS NEEDED

In addition to your regular tools, you will need, at least, the following:

Crimping tool **NOTE:** **USE A QUALITY TOOL TO AVOID OVER-CRIMPING.**
Wire stripper
Continuity tester **CAUTION:** **DO NOT USE A TEST LIGHT TO TEST THE COMPUTER OR SENSOR WIRING OR YOU WILL DAMAGE THE COMPUTER.**

Electric drill
1 5/8" Hole saw (for the rubber grommet in the firewall)

4.0 PRE-INSTALLATION AND HARNESS ROUTING GUIDELINES

The installation of your harness kit will consist of two parts:

- ~ The physical routing, positioning, and securing of the harness, wire groups, and individual wires and connectors.
- ~ The proper electrical connection of the individual circuits.

We cannot tell you how to route the harness in your automobile. That depends a great deal upon the particular make of the automobile and what extent you want to secure and conceal the harness. We do offer some general guidelines and routing practices starting in **Paragraph 5.3**, general installation instructions in **Section 5.0**, and precise instruction concerning the electrical connections you will have to make beginning in **Section 6.0**. To help you begin thinking through the installation of your wire harness, read the following sections:

4.1 TRANSMISSION FUNCTION

If you are not using the 4L60E transmission, read **Paragraph 4.1.1**, then skip to **Paragraph 4.1.3**. If you **ARE** going to use 4L60E, then skip **Paragraph 4.1.1**, and start at **paragraph 4.1.2**.

- 4.1.1** If you **ARE NOT** using a 4L60E transmission, tape off and store the light blue/black and pink (brake switch) wires in the dash group and the 13-position (transmission) round connector in the tail section.
- 4.1.2** If you **ARE** going to use a 4L60E transmission then you **MUST** have a two-position vehicle speed sensor (VSS), and the correct brake switch. These are necessary to make the transmission work correctly. The brake switch should be closed (electrically connected) when the brakes **ARE NOT** being applied and open (not electrically connected) when the brakes **ARE** being applied. This is the opposite of a standard brake light switch. If you are using a pressure brake switch, a **SPDT** relay must be installed to unlock the converter when the brakes are applied. The vehicle speed sensor lets the computer know how fast the wheels are turning.
- 4.1.3** Regardless of whether you use the 4L60E or not, the vehicle speed sensor (VSS) and park/neutral indicator switch must be used and is needed by the computer so it can command the emissions control devices on the engine. This part is necessary if you want your car to be street-legal.

NOTE; Emission devices

This harness has provisions for 3 emission devices, which are EGR solenoid, Air Pump relay and a Canister Purge solenoid. We have rolled up the canister purge solenoid wiring and air pump wiring in the dash section and may be left there if these items are not to be used. If you plan on using the canister purge solenoid and air pump you will need to route these wires out to the engine compartment and install an air pump relay. Secure the wires to the main harness using the tie wraps supplied.

To keep the check engine light from coming on you will need to plug in a canister purge solenoid and air pump relay to the wires in the dash section. (The computer looks for signals from these controls and does not care if the actual devices are installed.)

4.2 YOU SHOULD GET TO KNOW THE PARTICULAR ENGINE YOU ARE USING:

NOTE: The 94 & 95 LT1 engine has two oxygen sensors, one on the right side and one on the left side of the engine. This system has four rectangular connectors at the computer. A 16188051 computer is required for proper operation.

- 4.2.1** PPPI recommends the use of the following parts. See **Table 4.1**. These will meet all requirements and are compatible with PPPI harnesses. The numbers given are GM and AC Delco part numbers. **You must use the computer listed on table 4.1 with our harness.**
- 4.2.2** Familiarize yourself with the harness by locating each of the harness groups and by looking at the connectors on the wire ends.
- 4.2.3** Decide where and how the computer, fuse block and relays will be mounted. PPPI wire harness kits are designed to mount either under the dash or in the kick panel on the right side. They must be no further apart than the wiring will allow (approx. 16 inches).
- 4.2.4** A good exercise is to lay out the wire harness on the floor beside your vehicle and identify all the connectors and wires.
- 4.2.5** You will want to route the harness through and around open areas. Inside edges provide extra protection from hazards and also provide places for tie wraps, clips and other support.
- 4.2.6** Route the harness away from sharp edges, exhaust pipes, and the hood, trunk and door hinges.
- 4.2.7** Plan where harness supports will be located. Use a support approximately every 6 inches unless the harness routes under the floor carpet.
- 4.2.8** Allow enough slack in the harness at places where movement could possibly occur (body to frame, frame to engine, etc.).
- 4.2.9** The wires should be bundled into harness groups. Use tape, nylon ties or poly split loom.

LT1 Fuel Injection Harness (94 & 95) Part # 60502 or 60505

Main Computer.....Service#16188051	EGR. Solenoid..... Delco# 214-396
Brake Switch.....GM# 25524845	Gear Indicator Switch.....GM# 15705308 or
Intake Air Temperature.....GM# 12110319	Delco #D2286A
Ignition Module.....Delco# D-1986-A	MAP SensorGM# 16137039
Idle Air ControlGM# 17113099	Coolant Temperature SensorGM# 25036979
Knock SensorDelco# 213-96	
Coil.....Delco# D-573	Air Pump Relay....GM# 14100455 Delco# 15-8426
Oxygen Sensors...GM# 25312184 or Delco# AFS 75	Air Pump.....Delco# 2604-4885
TPS Sensor.....GM# 17106680	MAF Sensor.....Delco# 213-252
Canister Purge Solenoid GM# 1997201 Delco# 214-565	

NOTE: Components with part numbers other than the ones listed may plug into the 60502 or 60505 harness, but the part numbers MUST match the ones on this list for proper operation. An adapter is included to adapt the 4-pin square IAC connector to the '94-'96 flat 4-pin connector.

Table 4-1 Compatible Parts

5.0 GENERAL INSTALLATION INSTRUCTIONS

CAUTION:

- ~ **DO NOT DISCONNECT THE BATTERY OR THE COMPUTER CONNECTORS WHILE THE IGNITION IS ON.**
- ~ **DO NOT SHORT ANY WIRES IN THIS HARNESS TO GROUND (WITH THE EXCEPTION OF LABELED GROUND WIRES) OR DAMAGE TO THE COMPUTER WILL RESULT.**
- ~ **GIVING OR RECEIVING A "JUMP START" MAY DAMAGE THE COMPUTER.**
- ~ **DO NOT USE A TEST LIGHT WHEN TESTING COMPUTER SENSORS OR COMPUTER CIRCUITS. DAMAGE TO THE COMPUTER WILL RESULT!**
- ~ **WHEN ROUTING THE WIRES FOR THE VEHICLE SPEED SENSOR (IF USED) MAKE CERTAIN THAT THEY ARE AT LEAST 12 INCHES AWAY FROM ANY IGNITION WIRING (SPARK PLUG WIRES, ETC.).**

Notes:

- ~ **There is a normal, small current drain on these fuel injected systems.**
- ~ **Each connector in this harness is different and will not fit in the wrong place. NEVER FORCE ANY CONNECTOR.**
- ~ **When connecting the plugs to the computer USE EXTREME CARE to make sure none of the pins in the computer are or become bent.**
- ~ **The fuel pump you are using MUST be rated at a minimum of 45 PSI (pounds per square inch).**

5.1 GROUNDING THE VEHICLE

A perfectly and beautifully wired automobile will nevertheless have problems if everything is not properly grounded. Don't go to the effort to installing a quality wire harness only to neglect proper grounding.

Note: The installer of this harness is responsible for all ground wires not provided with this part.

5.1.1 Connect a ground strap or cable (minimum of a 4 Ga. wire) from the negative battery terminal to the chassis (frame).

5.1.2 Connect a ground strap (minimum of a 4 Ga. wire) from the engine to the chassis (frame). **DO NOT RELY UPON THE MOTOR MOUNTS TO MAKE THIS CONNECTION.**

5.1.3 Connect a ground strap from the engine to the body.

5.2 ROUGH INSTALLATION

CAUTION: DISCONNECT THE POWER FROM YOUR VEHICLE BY REMOVING THE NEGATIVE BATTERY CABLE FROM THE BATTERY.

Note: Make no wire connections or permanent mounting of any kind at this time.

- 5.2.1 Position the computer and sensors in their intend locations.
- 5.2.2 Drill a 1-5/8" hole for the firewall grommet near the computer for the engine group and tail section to pass through.
- 5.2.3 Route the engine group and tail section through the hole. Push the grommet (already installed on the harness) into the hole until it is seated.
- 5.2.4 Route the dash group over to the driver's side of the car.
- 5.2.5 Route the fuse block and relays to the place they will be mounted.

5.3 HARNESS ATTACHMENT

Note: Harness routing and shaping will be a time-consuming task. Taking your time will enhance the beauty of your vehicle. Please take your time and be patient.

- 5.3.1 Permanently mount your computer. You should mount the fuse block and relays at this time.
- 5.3.2 Mold harness groups to the contour of the dash, engine, frame, etc. Remember to route harness away from sharp edges, exhaust pipes, hinges, and moving parts.
- 5.3.3 Attach harness groups to your automobile with clips or ties starting at the computer and working your way outward.

Note: Do not tighten tie wraps or mounting devices at this time. Make all harness attachments LOOSELY.

- 5.3.4 When used every 1-1/2" or so on the visible areas of the harness, colored plastic wire ties make a very attractive assembly. Otherwise, a tie installed in other areas every 6" or so will hold the wires in place securely. **REMEMBER TO TAKE YOUR TIME.**

5.4 TERMINAL INSTALLATION INSTRUCTION

Note: In the following steps you will be making the circuit connections. Before you start, you should carefully read Sections 6.0, and continually refer to the wire charts, DOUBLE CHECKING your length calculations before cutting any wire or making any connections. These directions are for the wires, which do not have a connector already, installed on them.

- 5.4.1 Have all tools and connectors handy.
- 5.4.2 Select the correct terminal for the wire and application.
- 5.4.3 Determine the correct wire length and cut the wire. Remember to allow enough slack in the harness and wires at places where movement could occur. **DOUBLE CHECK YOUR CALCULATIONS.**
- 5.4.4 Strip insulation away from wire. Only strip as much insulation off as necessary for the type of terminal lug you are using.

Note: In the following step, make sure that the terminal is crimped with proper die in the crimping tool. An improper crimp will not make a good connection. DO NOT OVER-CRIMP.

- 5.4.5 Crimp the terminal onto the wire.
- 5.4.6 Connecting the wires and connectors throughout the harness is a simple process. Make sure that each wire is properly routed and then attached. **DO NOT ATTACH THEN ROUTE AFTERWARD.**
- 5.4.7 When all the wires are attached, tighten the mounts and ties to secure the harness permanently.
- 5.4.8 Attach the connectors to the computer. **BEING VERY CAREFUL NOT TO BEND ANY PINS.**
- 5.4.9 After all connections have been made throughout the harness, connect the battery to the vehicle.

CAUTION: BE SURE THE IGNITION IS OFF WHEN YOU RECONNECT THE BATTERY OR YOU WILL DAMAGE THE COMPUTER.

6.0 GM 94 & 95 LT1 SYSTEM WIRE HARNESS INSTALLATION INSTRUCTIONS

6.1 CONTENTS OF THE 60502 OR 60505 WIRE HARNESS KIT

Take inventory to see that you have everything you are supposed to have in this kit. If anything is missing, contact the dealer where you obtained the kit or contact Painless Performance at (817) 244-6898. The kit should contain the following items:

- ~ The main wire harness with the connectors already on the ends of most of the wires.
- ~ Fuel Injection Installation Instructions P/N 90517 (This Booklet).
- ~ WH 427 ECM data wire (purple)

6.2 SPECIFIC CIRCUIT CONNECTIONS

Note: If you have not already done so, read sections 4.0 and 5.0 of these instructions and think through the installation of the harness before securing or cutting any wires.

6.2.1 DASH SECTION INSTALLATION

The wires in this group consist of the diagnostic link connector (DLC) (SEE **FIGURE 6.1**), the check engine light (pre-mounted into a mounting bracket), and 13 other wires.

Note: You may need to connect the check engine light wires to their mates in the wire harness.

CAUTION: DO NOT MAKE ANY CONNECTIONS WHILE THE COMPUTER IS PLUGGED INTO THE HARNESS.

Note: Wire color (Example: Blk/Wht) is one wire with a stripe. The second color (the stripe) may not be bold. Observe all two-color wires closely.

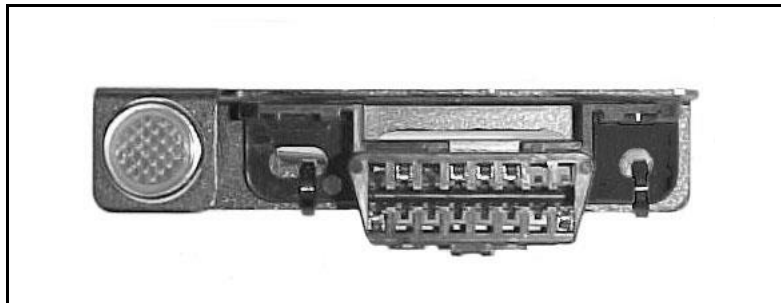

FIGURE 6.1 DLC Connector & Check Engine Light

- A.** Find a suitable location to mount the DLC connector (using the bracket that the light is mounted in) that will allow access to the front of the connector and still allow you to see the light while driving.

NOTE: If using a 1997 computer you will have to install the serial data wire provided in this kit. This wire connects into port number 7 in the Blue connector in your ECM, and to the number 2 port in the DLC connector

- B.** Mount the DLC connector using the bracket containing the check engine light in the place selected.
- C.** Locate the pink ignition hot activation wire, labeled "fuse block ignition B+ (18 Ga.) for the fuse block and attach it a 12V **fused** power source where there is power

WHEN THE KEY IS IN THE START AND RUN POSITION. This is the power wire for the fuel injection harness. If the pink wire is connected correctly, the check engine light will come on when the ignition is "ON or START".

- D.** Locate the Orn/Blk and Blk/Wht wires in the dash group. These two wires are for the Park/Neutral **INDICATOR** Switch, **NOT** the Neutral Safety Switch. If you have a GM column then you can use the combination switch P/N 15679680 and wire it as described in paragraph 2 or 3 below. The ORN/BLK wire needs to be grounded in "Park and Neutral" and ungrounded in "Drive". This can also be done with a toggle switch or a switch on the parking brake.

CAUTION: DO NOT CONNECT THESE WIRES USING DIRECTIONS FROM DIFFERENT PARAGRAPHS. YOU MAY DAMAGE THE COMPUTER.

- D.1.** If you are **NOT** using a vehicle speed sensor (VSS) or Park/Neutral Indicator Switch then you will need to connect these two wires together.

Note: If you do this, the computer will stop controlling the exhaust gas recirculation (EGR) solenoid. THIS WILL PREVENT THE SYSTEM FROM BEING STREET-LEGAL.

- D.2.** If you are going to use the recommended switch for the computers benefit **ONLY**, then you will wire it as shown in **Illustration A**.

- D.3.** The recommended switch is a combination reverse light **AND** neutral safety switch. You may use it for these purposes **AND** the computer signal **IF** you wire it **EXACTLY** as shown in **Illustration B**.

- D.4.** You may want to install your own switch. This switch must connect the Orn/Blk wire to ground only when the car is in **PARK OR NEUTRAL**. You may or may not want to use the Blk/Wht wire. The other end of the Blk/Wht wire is already grounded throughout the harness.

- E.** The single light blue wire is the wire that lets the computer know when the brake is applied. If you **ARE NOT** using a 4L60E then you will tape off and store this wire. If you **ARE** using the 4L60E transmission then you will have to install an electrical switch described in **Paragraph 4.1.2**. The pink wire provides power for this switch.

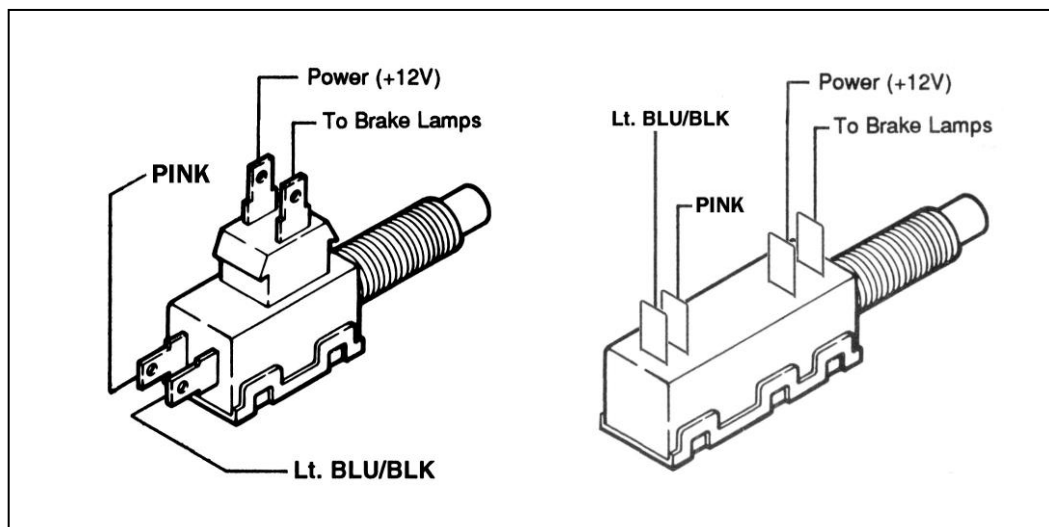

FIGURE 6.2 Brake Switch Connection

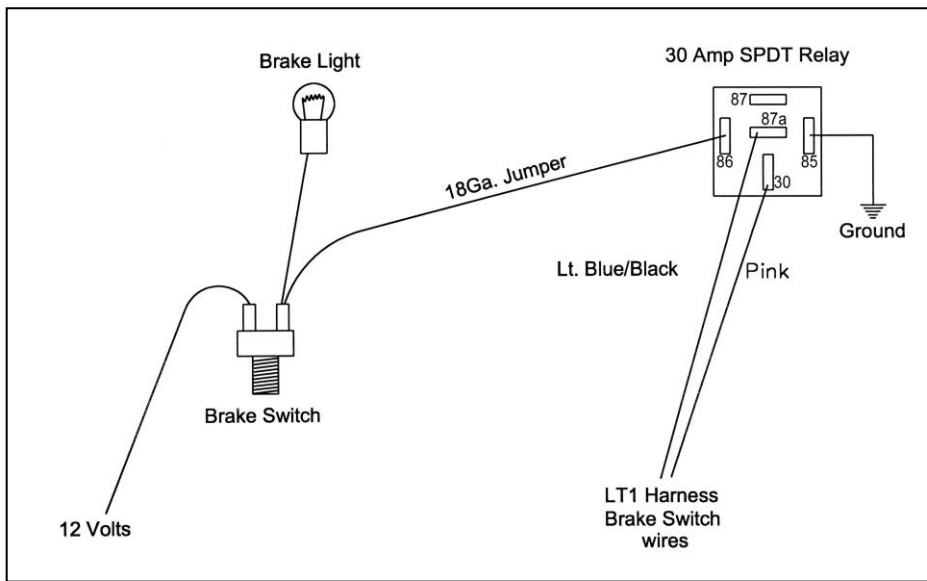

FIGURE 6.3 Brake Switch Relay

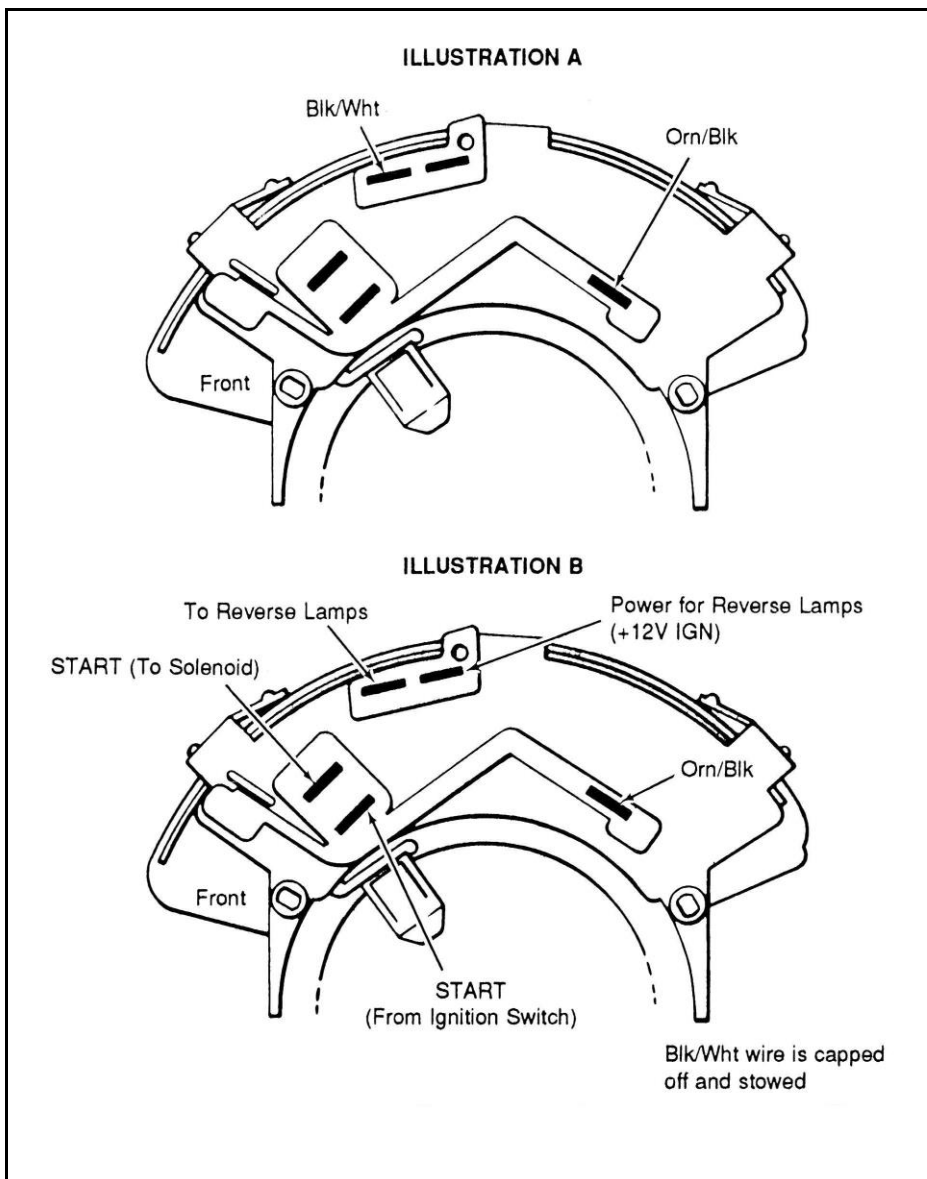

FIGURE 6.4 Gear Indicator Switch

- F. If you are using the recommended brake switch then you will wire it according to **Figure 6.2**. The pink wire to the back of the switch in the illustration is the wire that has power on it whether or not the brake is being applied.

CAUTION: FAILURE TO WIRE THIS SWITCH CORRECTLY WILL RESULT IN A DANGEROUS SITUATION ON THE VEHICLE.

- G. If your vehicle has a pressure type brake switch, you may use a relay as shown in Figure 6.3. The relay must be a **SPDT Relay** and wired correctly or it could result in a dangerous situation with the vehicle. The torque **converter may not unlock**.

The fuel pump connector has a small gray wire at the bottom of it that terminates in a female connector. This wire is a test point for the fuel pump. After the vehicle has been wired and tested OK, tape off this wire and store it in the harness.

- H. The wires labeled VATS (lt. green, red and black) are to be connected to the matching wires on the VATS module supplied in the kit.

- I. Fan #1 relay wire (green) and fan #2 relay wire (blue) are relay ground wires activated by the computer.

Note: The green wire labeled A/C CLUTCH B+ splices (using the blue T-Tap in the parts bag) into the ignition hot wire going to the A/C compressor clutch. This is the A/C REQUEST wire.

- J. The wire labeled TACH (white) is the signal wire for a tachometer is used.

- K. The VSS output wire sends out a signal to operate the electronic cruise control or speedometer if so equipped.

6.2.2 Dash Section Connections

WIRE COLOR	# OF POSITIONS IN CONNECTOR	LABELED	CONNECT TO:
Brown (4) Red (2)	4	Air Pump Relay	Relay
Brown, Green/White	2	Canister Purge	Canister Purge Solenoid
Black, Red (2)	3	Air Pump	Air Pump
Gray, Green/White, Black/White, Pink	4	Fuel Relay	Fuel Pump Relay
Green/White		VSS Output	Speedometer/Cruise
White		Tach	Tachometer
Orange/Black, Black/White		P/N switch	Park/Neutral Switch
Pink, Light Blue/Black		Brake Switch	Brake Switch
Pink		Fuse Block B+	Ignition Power

TABLE 6.1 Dash Section Connections

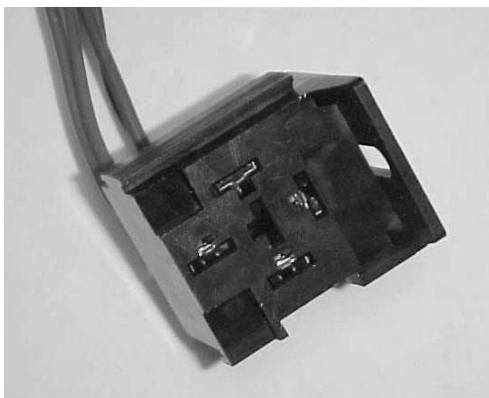

FIGURE 6.5 Air Pump Relay Connector

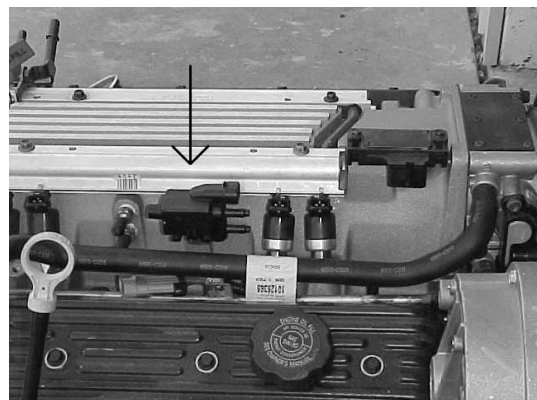

FIGURE 6.6 Canister Purge Solenoid

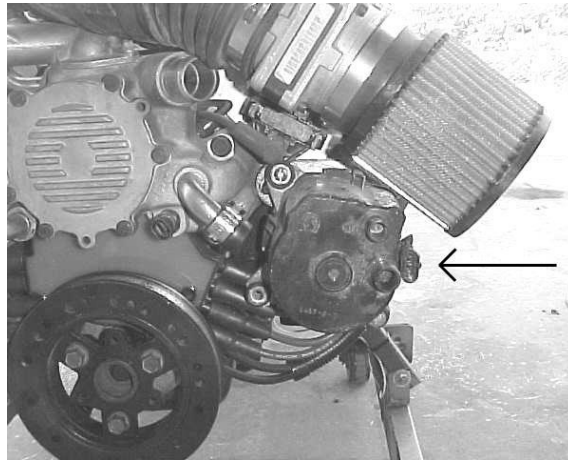

FIGURE 6.7 Air Pump Connection

6.3 ENGINE GROUP INSTALLATION

The engine group is designed to be separated into left side (driver) and right side (passenger) sections. Each side is tie-wrapped separately, **BUT NOT LABELED**. The right side of the engine has the connectors for the idle air control, throttle position sensor, distributor, and map sensor, all of which **ARE** labeled. When you begin routing, **FIRST** separate the engine group into left and right sections and place them accordingly.

- 6.3.1** Before you connect any wires, separate the tail section from the engine group and place it out of the way.
- 6.3.2** Locate the two Blk/Wht wires in the harness that end in a single, large ring terminal and ground them to the engine.
- 6.3.3** Using **Figure 6.4-6.8**, and the specific connections indicated in **Table 6.1**, connect the wiring as directed.

NOTE: The air pump connector is rolled up in the dash section and must be routed out to the engine compartment if the air pump is to be operational. See section 4.1 Paragraph 4.1.3

- 6.3.4** Check to make sure that the 60502-wire harness has the correct distributor connector on it for your particular engine. There are two different connectors used on LT1 engines. The 92 & 93 engines used a short connector, 1" long and the 94 and up engines use a 2" connector. This 60502 harness has the 2" connector made on it. You may reuse the original connector or contact Painless Performance for a 1" pigtail connector.
- 6.3.5** The pink wire labeled coil power needs to be connected to the wire that powered the coil on the original engine.

6.3.6 Engine Section Connections

WIRE COLOR	# OF POSITIONS IN CONNECTOR	LABELED	CONNECT TO:
Brown, Gray	2	EGR	EGR Solenoid
Blue	1	Knock	Knock Sensor
Purple/White, Tan/White, Brown, Black	4	Driver Side Oxy	Left Oxygen Sensor
Purple, Tan, Brown, Black	4	Pass. Side Oxy	Right Oxygen Sensor
Red	Ring Terminal (2)	Starter B+	Starter Solenoid
Gray, Light Green, Black	3	MAP	Map Sensor
Pink, Black	2	Inj # 1	Drivers Side Front Inj
Pink, Light Green/Black	2	Inj # 2	Pass Side Front Inj
Pink, Pink/Black	2	Inj # 3	Drivers Side 2nd Inj
Pink, Light Blue/Black	2	Inj # 4	Pass Side 2nd Inj
Pink, Black/White	2	Inj # 5	Driver s Side 3rd Inj
Pink, Yellow/Black	2	Inj # 6	Pass Side 3rd Inj
Pink, Red/Black	2	Inj # 7	Drive rs Side 4th Inj
Pink, Blue/White	2	Inj # 8	Pass Side 4th Inj
Gray, Black, Blue	3	TPS	Throttle Position Sensor
Light Green/Black, Light Green/White			
Light Blue/Black, Light Blue/White	4	IAC	Idle Air Control Motor
Yellow, Black/White, Pink	3	MAF	Mass Airflow Sensor
Red/Black, Pink/Black,			
Red, Light Blue/Black	4	DIST	Distributor
White, Black, Pink/Black, White/Black	4	IGN MOD	Ignition Module
Pink, White	2	Coil	Ignition Coil
Pink/Black, White/Black	2	Coil	Ignition Coil
Black, Yellow	2	ECT	Engine Coolant Temp.Sensor
Black, Tan	2	IAT	Intake Air Temp Sensor
Black, Black/White (3)	Ring Terminal (2)	Ground	Engine Ground
Pink		Coil Power	Power For Coil

TABLE 6.2 Engine Section Connections

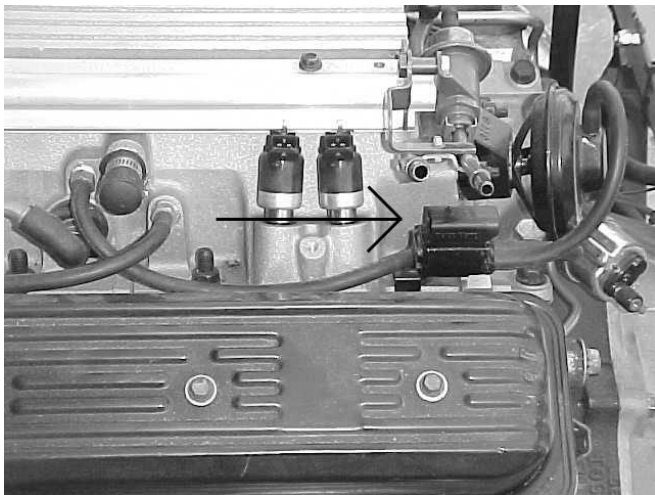

FIGURE 6.9 EGR Solenoid

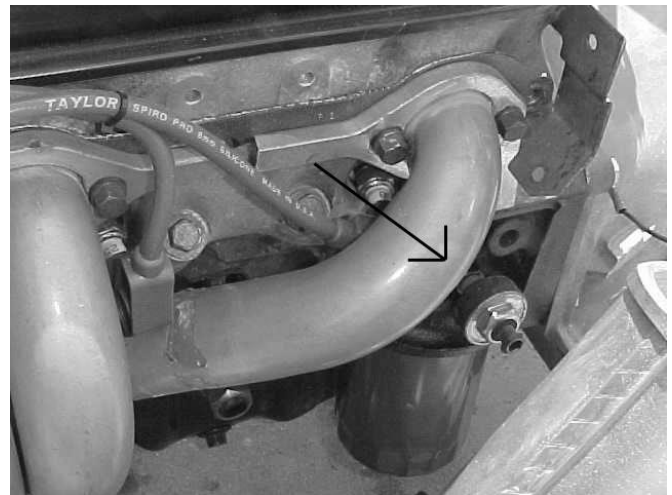

FIGURE 6.10 Knock Sensor



FIGURE 6.11 Oxygen Sensor

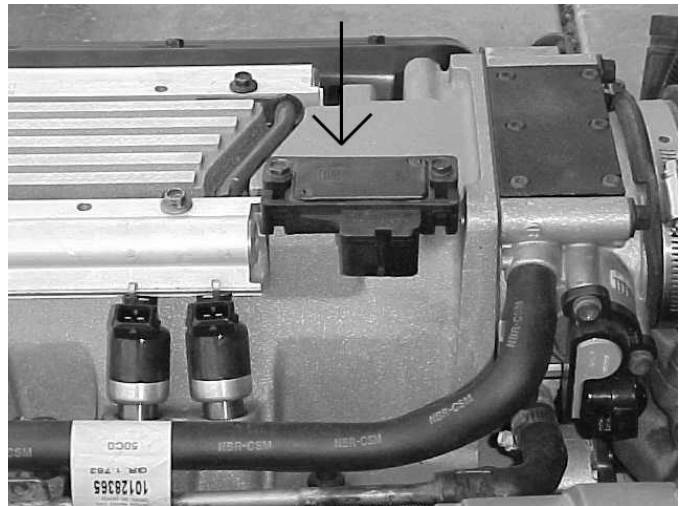

FIGURE 6.12 MAP Sensor



FIGURE 6.13 Injectors 1, 3, 5, 7

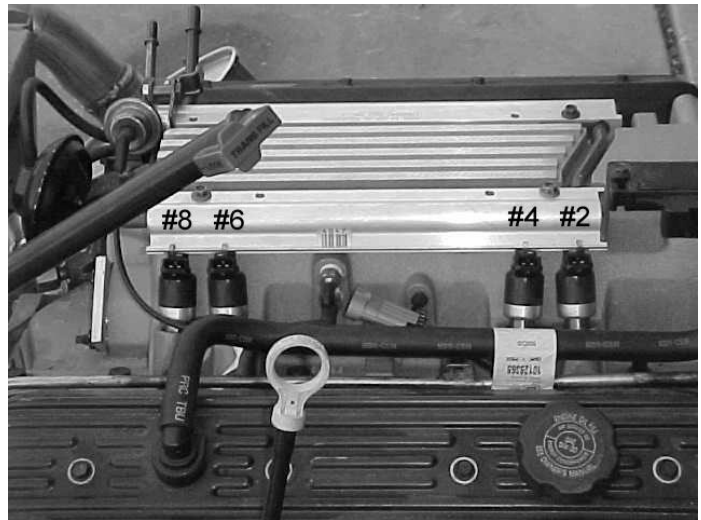

FIGURE 6.14 Injectors 2, 4, 6, 8



FIGURE 6.15 TPS Sensor

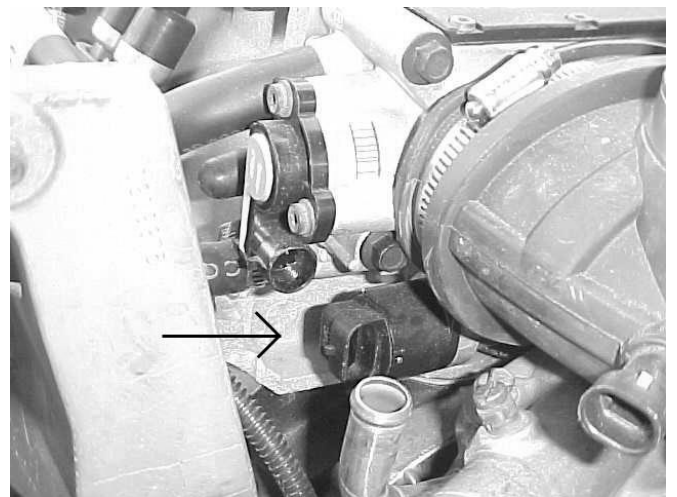

FIGURE 6.16 IAC

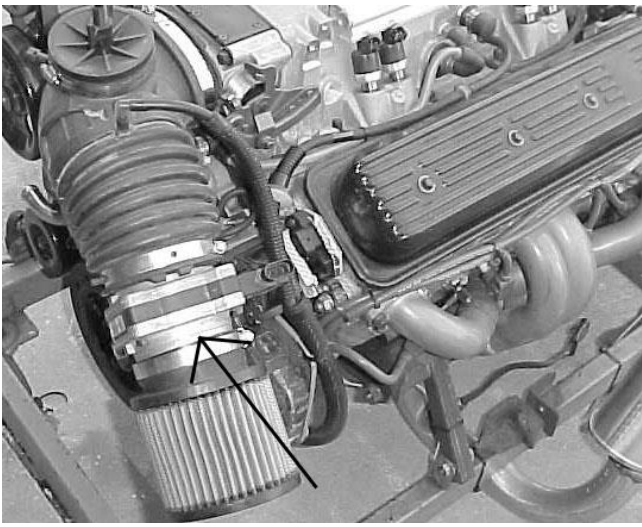

FIGURE 6.17 MAF Sensor

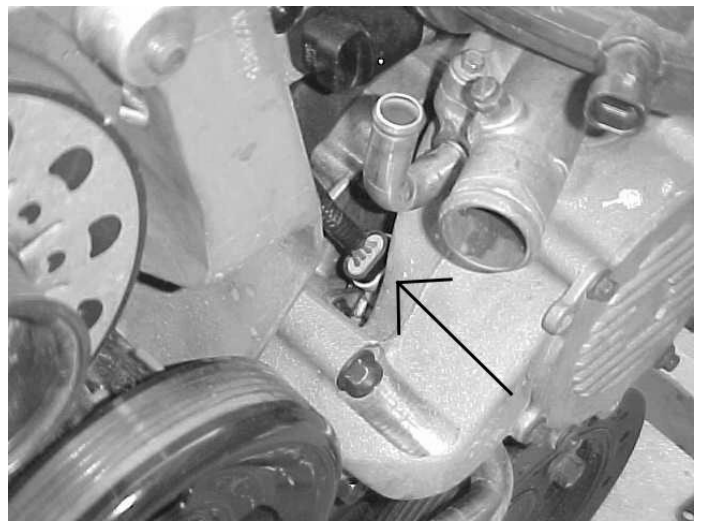

FIGURE 6.18 Distributor

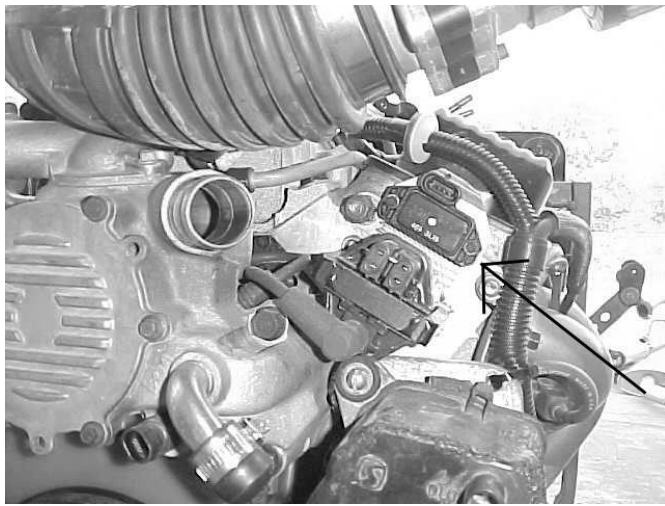

FIGURE 6.19 Ignition Module



FIGURE 6.20 Coil

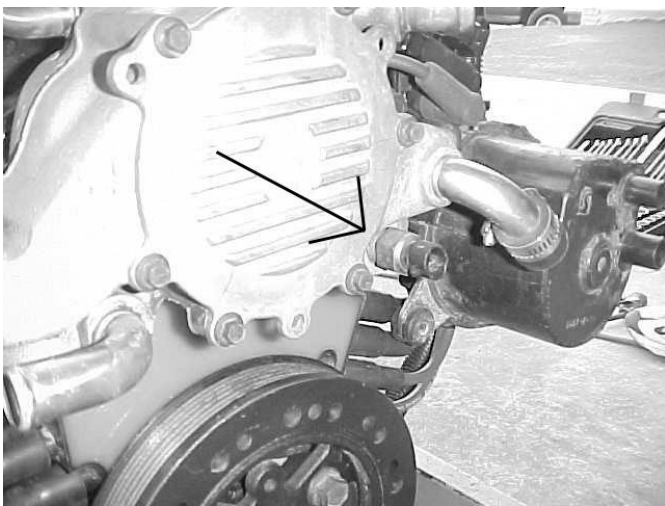

FIGURE 6.21 ECT Sensor



FIGURE 6.22 IAT Sensor

6.4 TAIL SECTION INSTALLATION

- 6.4.1 Locate the tail section that you earlier separated from the engine group. Begin routing it towards the rear of the vehicle. Be sure to avoid all sharp edges, moving or hot parts, or anything else that may damage the harness.
- 6.4.2 If you **ARE** using the 4L60E transmission, route the 13-position connector to the transmission and attach it.
- 6.4.3 If you **ARE NOT** using the 4L60E transmission, tape up the connector and store it in the harness.
- 6.4.4 Take the gray wire and route it to the fuel pump. This is the power wire for the fuel pump.
- 6.4.5 Take the connector for the Vehicle Speed Sensor (VSS) and connect to the Vehicle Speed Sensor.

6.4.6 Tail Section Connections

WIRE COLOR	# OF POSITIONS IN CONNECTOR	LABELED	CONNECT TO:
Purple, Yellow	2	VSS	Speed Sensor
Gray		Fuel Pump	Fuel Pump
Light Green, White, Light Blue/White, Tan/Black, Brown, Pink, Yellow/Black, Red/Black, Pink/Black, Blue, Red, Yellow/White, Black	13	Trans	Transmission

TABLE 6.3 Tail Section Connections

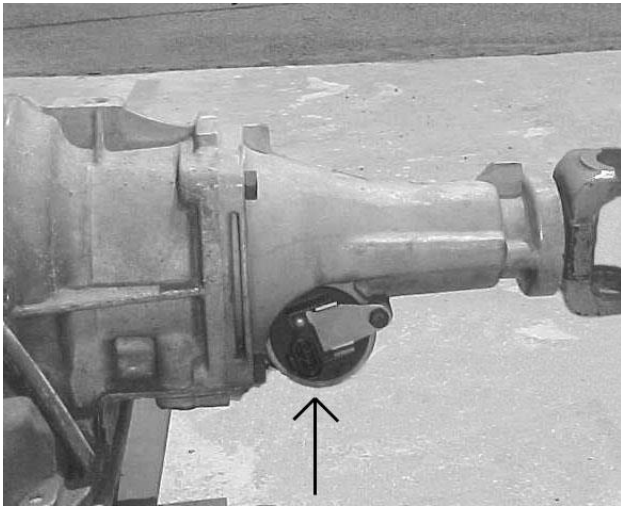

FIGURE 6.23 VSS

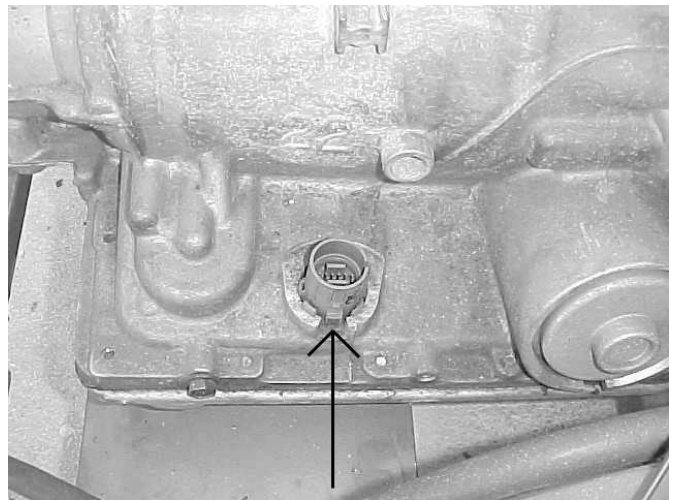

FIGURE 6.24 Transmission Connection

7.0

TROUBLE- SHOOTING INSTRUCTIONS

If you are having trouble with your engine running badly or not running at all, first perform basic trouble-shooting (ensure that you are using the correct parts (Table 4.1), check for faulty connections, blown fuses, connection of VATS module, spark, timing, fuel pressure, etc.), then see if the computer has stored a trouble code in its memory.

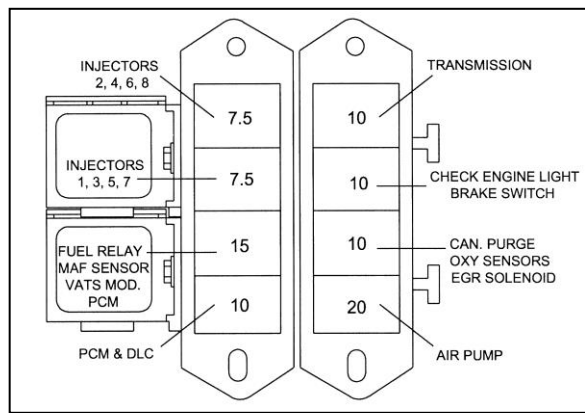

FIGURE 7.1 Fuse Identification

7.1 THE "CHECK ENGINE" LIGHT

Normally, the "check engine" light should come on when the ignition is turned on, then go out a few moments after the engine starts running. If it reappears, or stays on while the engine is running, the computer has detected a problem and a trouble code has been set.

7.2 RETRIEVING TROUBLE CODES FROM THE COMPUTER

The chart below shows the type of ALDL test connector each vehicle came with from the factory. If you are using a computer with '94 Camaro/Firebird, '94-'95 Caprice or '95 Impala programming you must install the **OBD 1** connector. **We have included this connector as a pig tail assembly.**

If you need to install the OBD 1 connector start by cutting the zip ties holding the OBD 11 connector to the check engine light bracket. After you disconnect the negative battery cable you can cut the 5 wires coming from the OBD 11 connector. The cut ends of Orange and Black wires should be insulated and zip tied so that they will not short. You can now use the supplied butt connectors to connect the Black/White, White/Black and Tan wires coming from the harness to the matching wires coming from the OBD 1 pig tail. Install the OBD 1 connector on the check engine light bracket where you removed the OBD 11 connector from, using the supplied zip ties. If you have any issues with this process please contact the Painless Performance Tech line at 1-800-423-9696.

	1994	1995	1996
Camaro	OBD 1	OBD 11	OBD 11
Firebird	OBD 1	OBD 11	OBD 11
Caprice	OBD 1	OBD 1	OBD 11
Impala	-----	OBD 1	OBD 11

7.2.1 In order to retrieve the trouble codes stored in the computer, a scanner must be connected to the Assembly Diagnostic Link (DLC) connector (installed and connected in **Paragraph 6.2.1**). Follow the instructions provided with the scanner to read the codes set in the computer.

7.2.2 After you have read any codes, write them down for reference. Remove the connector from the DLC connector.

7.2.3 Take the codes one at a time and match them to the codes in **Table 7.1**. This will tell you in which circuit the computer has detected a problem.

Note: **A code indicates a problem in a specific circuit, NOT THAT A PARTICULAR PART IS BAD.**

7.2.4 Before taking more extensive corrective actions for any trouble codes, make sure that all connections on the indicated circuit, **INCLUDING THE COMPUTER**, are clean and tight. Inspect the wiring in the circuit for any broken, shorted, or exposed wires. Finally, insure all ground wires are clean and secure.

7.2.5 If a trouble code is detected and the problem has been fixed, clear the codes by first making sure the ignition is off then disconnecting the **NEGATIVE** battery cable for at least 3 minutes.

7.2.6 Trouble Code Chart, Diagnostic Trouble Code (DTC)

DTC 11 = Malfunction Indicator Lamp
DTC 13 = Bank 1 (left) Heated Oxygen Sensor (HO2S) Open Circuit
DTC 14 = Engine Coolant Temperature (ETC) Sensor Circuit (Signal Voltage Low) Overheated
DTC 15 = Engine Coolant Temperature (ETC) Sensor Circuit (Signal Voltage High) Engine cold
DTC 16 = Distributor Ignition System (Low Resolution Pulse)
DTC 18 = Injector Circuits
DTC 21 = Throttle Position (TP) Sensor Circuit (Signal Voltage High)
DTC 22 = Throttle Position (TP) Sensor Circuit (Signal Voltage Low)
DTC 23 = Intake Air Temperature (IAT) Sensor Circuit (Signal Voltage High) Cold Intake Air
DTC 24 = Vehicle Speed Sensor (VSS) Circuit
DTC 25 = Intake Air Temperature (IAT) Sensor Circuit (Signal Voltage Low) Hot Intake Air
DTC 26 = Evaporative Emission (EVAP) Canister Purge Solenoid Valve Circuit
DTC 27 = Exhaust Gas Recirculation (EGR) Vacuum Control Solenoid Valve Circuit
DTC 28 = Transmission Range (TR) Pressure Switch Assembly Fault
DTC 29 = Secondary Air Injection (AIR) Pump Circuit
DTC 32 = Exhaust Gas Recirculation (EGR)
DTC 33 = Manifold Absolute Pressure (MAP) Sensor Circuit (Signal Volts High, Low Vacuum)
DTC 34 = Manifold Absolute Pressure (MAP) Sensor Circuit (Signal Volts Low, High Vacuum)
DTC 36 = Distributor Ignition System (Faulty High or Extra Low Resolution Pulse Detected)
DTC 37 = Brake Switch Stuck "ON"
DTC 38 = Brake Switch Stuck "OFF"
DTC 41 = Ignition Control (IC) Circuit (Open Circuit)
DTC 42 = Ignition Control (IC) Circuit (Shorted or Grounded Circuit)
DTC 43 = Knock Sensor (KS) Circuit
DTC 44 = Bank 1 (Left) Heated Oxygen Sensor (HO2S) Circuit (Lean Exhaust Indicated)
DTC 45 = Bank 1 (Left) Heated Oxygen Sensor (HO2S) Circuit (Rich Exhaust Indicated)
DTC 46 = Pass-Key Circuit
DTC 47 = Knock Sensor (KS) Module Circuit or Module Missing
DTC 48 = Mass Air Flow (MAF) Sensor Circuit
DTC 50 = System Voltage Low
DTC 51 = EEPROM Programming Error
DTC 53 = System Voltage High
DTC 55 = Fuel Lean Monitor
DTC 58 = Transmission Fluid Temperature (TFT) Sensor Circuit Low (High Temp Indicated)
DTC 59 = Transmission Fluid Temperature (TFT) Sensor Circuit High (Low Temp Indicated)
DTC 61 = A/C System Performance
DTC 63 = Bank 2 (Right) Heated Oxygen Sensor (HO2S) Circuit (Open Circuit)
DTC 64 = Bank 2 (Right) Heated Oxygen Sensor (HO2S) Circuit (Lean Exhaust Indicated)
DTC 65 = Bank 2 (Right) Heated Oxygen Sensor (HO2S) Circuit (Rich Exhaust Indicated)
DTC 66 = A/C Refrigerant Pressure Sensor Circuit (Open or Shorted)
DTC 67 = A/C Refrigerant Pressure Sensor Circuit (Pressure Sensor or A/C Clutch Problem)
DTC 68 = A/C Relay Circuit (Shorted Circuit)
DTC 69 = A/C Clutch Circuit
DTC 70 = A/C Clutch Relay Driver Circuit
DTC 71 = A/C Evaporator Temperature Sensor Circuit (Open or Shorted)
DTC 72 = Vehicle Speed Sensor Loss (Automatic Transmissions Only)
DTC 73 = Pressure Control Solenoid (PCS) Circuit (Current Error)
DTC 74 = Traction Control Circuit (TCS) Circuit Low
DTC 75 = Transmission System Voltage Low
DTC 77 = Cooling Fan Relay Control Circuit
DTC 79 = Transmission Fluid Overtemp
DTC 81 = Transmission 2-3 Shift Solenoid Circuit
DTC 82 = Transmission 1-2 Shift Solenoid Circuit

DTC 83 = Reverse Inhibit System (Manual Transmission)
DTC 83 = TCC PWM Solenoid Circuit Fault (Automatic Transmission)
DTC 84 = Automatic Transmission 3-2 Control Solenoid Circuit
DTC 84 = Skip Shift Solenoid Circuit (Manual Transmission)
DTC 85 = Transmission TCC Stuck "ON"
DTC 90 = Transmission TCC Solenoid Circuit (Manual Transmission)
DTC 91 = Skip Shift Lamp Circuit
DTC 97 = VSS Output Circuit
DTC 99 = Tach Output Circuit

TABLE 7.1 Diagnostic Trouble Codes

7.3 WHEN TO CALL PAINLESS PERFORMANCE PRODUCTS' TECH LINE

7.3.1 These harness kits have been built with the highest regard to quality control. Before calling us please double check all connections and perform normal basic trouble-shooting (fuel pressure, timing, ignition system, etc.).

7.3.2 If you have any questions concerning the installation of this harness or having trouble in general, feel free to call Painless Performance Products' tech line at (817) 560-8324. Calls are answered from 8am to 5pm central time, Monday thru Friday, except holidays. Email questions to Tech@painlessperformance.com

Painless Performance Limited Warranty and Return Policy

Chassis harnesses, fuel injection harnesses, and Striker ColdShot units are covered under a lifetime warranty.

All other products manufactured and/or sold by Painless Performance are warranted to the original purchaser to be free from defects in material and workmanship under normal use. Painless Performance will repair or replace defective products without charge during the first 12 months from the purchase date. No products will be considered for warranty without a copy of the purchase receipt showing the sellers name, address and date of purchase. You must return the product to the dealer you purchased it from to initiate warranty procedures.