



350 S. St. Charles St. Jasper, In. 47546

Ph. 812.482.2932 Fax 812.634.6632

www.ridetech.com

Part # 19004900

4000lb. Air Over Leaf Kit – 2.5” Leaf / Side Frame

Components:

2	90006781	6.5” diameter double convoluted air spring
2	90002495	Leaf Spring Bracket
2	90002494	Leaf Spring Bracket Clamp
2	90000070	Air spring roll plate
2	90000002	Upper bolt-on bracket
2	31954201	¼” npt x ¼” tube 90 degree airline fitting

Hardware:

2	99371001	3/8” x ¾” USS bolt	Air spring to lower bracket
2	99373005	3/8” lock washer	Air spring to lower bracket
4	99371047	3/8” Carriage Bolt	Leaf Spring Bracket
10	99373003	3/8” SAE flat washer	Air spring mounting & Leaf Spring Bracket
8	99372002	3/8” USS Nylok nut	Air spring to upper brackets & Leaf Spring Bracket
8	99431002	7/16” x 1 1/4” USS bolt	Upper bracket to frame
8	99433002	7/16” USS flat washer	Upper bracket to frame
8	99432001	7/16” Nylok nut	Upper bracket to frame



350 S. St. Charles St. Jasper, In. 47546
Ph. 812.482.2932 Fax 812.634.6632
www.ridetech.com

**REAR INSTALLATION
SUPPLEMENT FOR MOUNTING AIRSPRING ON TOP OF LEAFSPRING**

1. This installation is performed with the vehicle at ride height. When you raise the vehicle to a comfortable working height, support it by the axle housing.
2. Attach the lower airspring bracket to the top of the leafspring, preferably behind the rearend, using the attachment hardware provided. On some models, the lip of the airspring bracket will locate in the axle plate. **NOTE:** On some vehicles, a softer ride is obtained by removing leafs from the spring pack. Be sure to leave at least 2 leafs in the spring pack for stability.
3. Attach the airspring to the lower bracket.
4. The upper bracket can now be attached to the airspring and its placement on the framerail can be determined. If the leafspring is under the frame, the upper bracket will be a "J" shaped piece that the airspring screws into. If the leafspring is beside the frame, the upper bracket will be an angle bracket that will bolt on to the frame. Using the proper inflated dimensions, check for airspring clearance to nearby obstacles. [Refer to the airspring dimension chart.] Note that the proper inflated dimensions will not be the same as the uninflated dimensions.
5. Mark the bolt holes for drilling or clamp in place to weld. [Remove airspring before welding to avoid weld splatter damage!]
6. Reassemble, inflate, and re-inspect for proper clearance.

NOTE: On the 88 -99 GM 1-ton chassis the F6957 airspring should be placed *BEHIND* the axle for the best clearance and the most load capacity.

REMEMBER: THE AIRSPRING BELLOWS MUST NOT TOUCH ANYTHING AT ANYTIME!! IT IS THE FINAL RESPONSIBILITY OF THE INSTALLER TO DETERMINE ADEQUATE CLEARANCE.

PLEASE CALL RIDETECH IF YOU HAVE ANY QUESTIONS.

Installation using 7000 Series or 9000 Series airspring

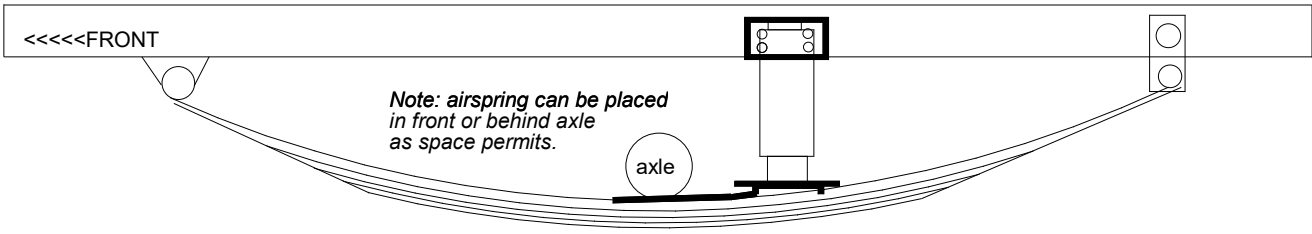

Installation using F6957 Airspring

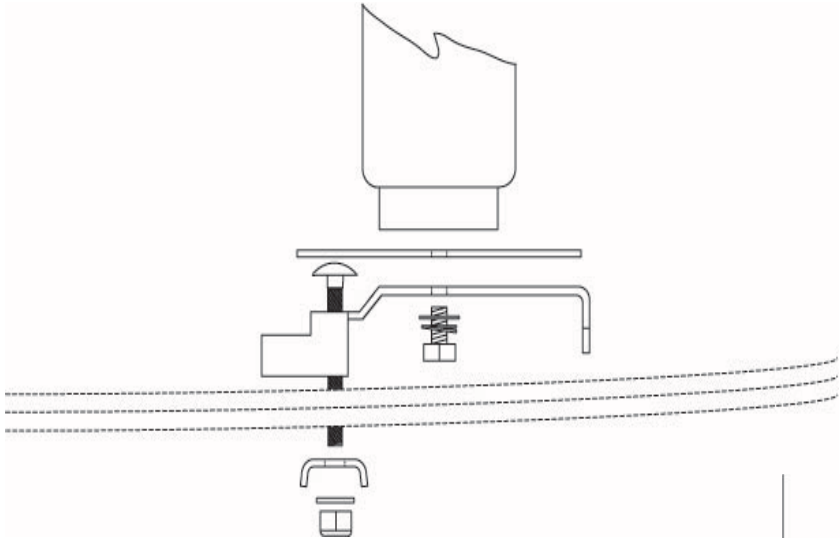
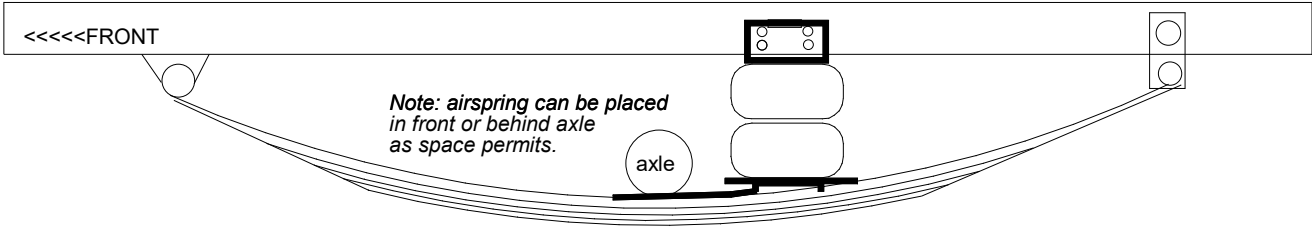

SIDE VIEW OF ASSEMBLY

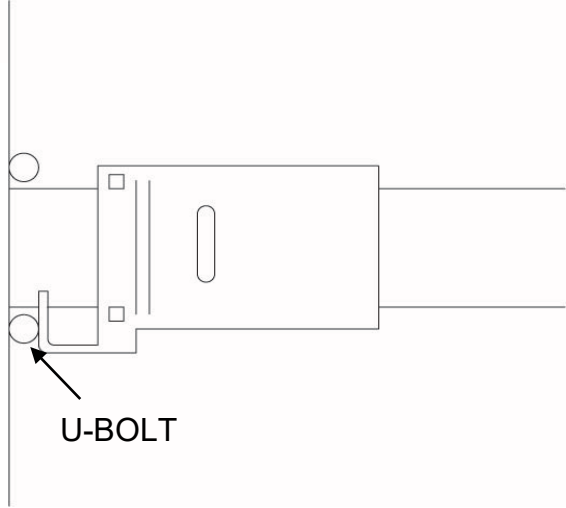
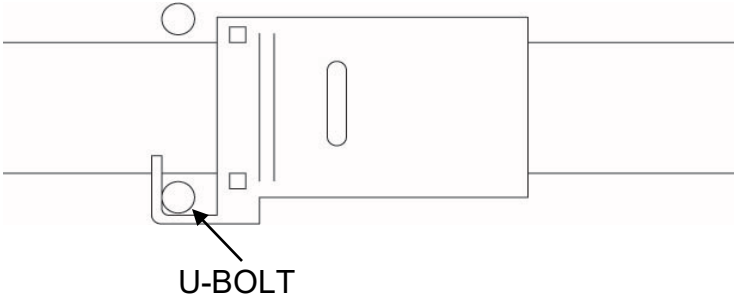

THE LEAF SPRING BRACKET CAN BE INSTALLED HOOKED ON THE U-BOLT OR TOUCHING U-BOLT AS SEEN IN ABOVE ILLUSTRATIONS.

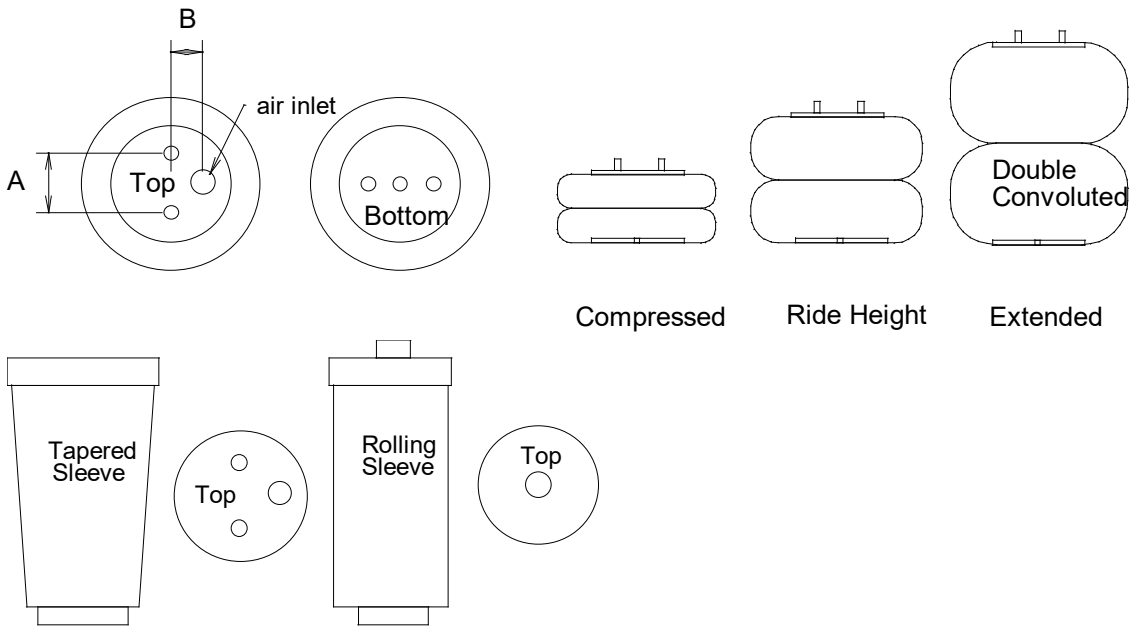

AIRSPRING DIMENSION CHART

PART#	TYPE	Capacity @100psi	Compress Height	Ride Height	Max. Height	Max Diameter	Bolt Pattern
255C [F6957]	Double Convoluted	2040#	3"[built in bumpstop]	4.5"-5.5"	7"	6.5"	A=1.75 B=.875
224C [F0335]	Double Convoluted	3150#	3"	5"-6"	8"	8.0"	A=2.75 B=1.312
26C [F7325]	Double Convoluted	3400#	3"	5"-6"	10"	8.5"	A=2.75 B=1.312
20 [F6908]	Double Convoluted	4790#	3"	7"-8"	11"	9.9"	A=3.50 B=1.75
F9000	Tapered Sleeve	1500#	4.5	8"-9.5"	13"	5"	A=2.75 B=1.312
F9002	Tapered Sleeve	1500#	4.5	7"-8.5"	12"	5"	A=2.75 B=1.312
F9003	Tapered Sleeve	1500#	4.5	6"-7"	11"	5"	A=2.75 B=1.312
F9010	Tapered Sleeve	2000#	6.5"	10.5"-11.5"	16"	6.5"	.750 SAE/.250npt
7012	Rolling Sleeve	1020#	4"	7.5"-8.5"	13"	5"	.750SAE/.125npt
7076	Rolling Sleeve	800#	2.25"	5"-6"	9"	4"	.750SAE/.125npt

CAUTION!!! EXCEEDING THESE DIMENSIONS MAY RESULT IN SUDDEN AIRSPRING FAILURE! PROPER CLEARANCES MUST BE MAINTAINED AT ALL RIDE HEIGHTS AND STEERING ANGLES. BUMPSTOPS MUST BE USED TO LIMIT SUSPENSION TRAVEL BEFORE THESE DIMENSIONS ARE EXCEEDED.