



Wire Harness Installation Instructions

For Installing:

**Part #60510 & 60511
Ford 5.0L or 5.8L 1986-93 Wiring Harness**

Manual #90518



**Perfect Performance Products, LLC
Painless Performance Products Division
9505 Santa Paula Drive, Fort Worth, Texas 76116-5929
(800) 423-9696**

We have attempted to provide you with as accurate instructions as possible, and are always concerned about corrections or improvements that can be made. If you have found any errors or omissions, or if you simply have comments or suggestions concerning these instructions, please write us at the address on the cover and let us know about them. Or, better yet, send us a fax at (817) 244-4024. We sincerely appreciate your business.

For Technical Questions

E-mail: tech@painlessperformance.com

Tech Line: 800-423-9696

Perfect Performance Products, LLC shall in no event be liable in contract or tort (including negligence) for special, indirect, incidental or consequential damages, such as, but not limited to, loss of property damage, or any other damages, costs or expenses which might be claimed as the result of the use or failure of the goods sold hereby, except only the cost of repair or replacement.

**P/N 90518 Painless Wiring Manual
June 2002**

Copyright © 2001 by Perfect Performance Products, LLC

TABLE OF CONTENTS

	List of Figures.....	i
	List of Tables.....	i
1.0	Introduction.....	1
2.0	About These Instructions.....	1
3.0	Tools Needed.....	1
4.0	Pre-Installation and Harness Routing Guidelines.....	2
5.0	General Installation Instructions.....	3
5.1	Grounding The Vehicle.....	4
5.2	Rough Installation.....	4
5.3	Harness Attachment.....	4
5.4	Terminal Installation Instructions.....	5
6.0	Ford 5.0 Wiring Harness Installation.....	6
6.1	Contents of the 60510 & 60511 Wire Harness Kits.....	6
6.2	Dash Section Installation	6
6.3	Engine Group Installation.....	11
6.4	Tail Section Installation.....	16
7.0	Ford 5.0 Start Up.....	17
8.0	Trouble-Shooting Instructions.....	17
8.1	The "Check Engine" Light.....	17
8.2	Retrieving Trouble Codes from the Computer.....	18
8.3	Engine Running.....	19
8.4	EEC-IV Diagnostic Trouble Codes and Definitions.....	19
8.5	When To Call Perfect Performance Products' Tech Line.....	20

LIST OF FIGURES

Figure 5.1	Computer & Harness Connector.....	5
Figure 6.1	Check Engine Light.....	7
Figure 6.2	Barometric Pressure Switch (BAP).....	7
Figure 6.3	Throttle Position Sensor (TPS).....	7
Figure 6.4	Intake Air Temperature & Engine Coolant Temperature (IAT & ECT).....	8
Figure 6.5	Idle Air Control Valve (IAC).....	8
Figure 6.6	Exhaust Gas Recirculation Valve (EGR).....	9
Figure 6.7	Thick Film Ignition (TFI).....	9
Figure 6.8	Mass Air Flow Sensor (MAF).....	10
Figure 6.9	Heated Oxygen Sensor (HEGO).....	10
Figure 6.10	EGR Vacuum Regulator Solenoid (EVR).....	13
Figure 6.11	Intake (with plenum removed).....	13
Figure 6.12	Location of EGR, TPS & ISC.....	14
Figure 6.13	Injector (numbered).....	15
Figure 6.14	Location of ACT & ECT.....	15
Figure 6.15	Vehicle Speed Sensor (VSS).....	16
Figure 6.16	Calibration Code.....	16
Figure 8.1	Self-Test Connectors (STO & STI).....	18
Figure 8.2	Fuse Location.....	20

LIST OF TABLES

Table 4.1	Compatible Parts.....	3
Table 6.1	Dash Section.....	11
Table 6.2	Engine Section.....	12
Table 6.3	Tail Section.....	17

1.0 INTRODUCTION

You have purchased what we at Perfect Performance Products, LLC believe to be the most up-to-date and easiest-to-install automotive fuel injection harness on the market. It is designed for easy installation, even if you have no electrical experience.

This harness is designed to be a complete wiring system for the fuel injection system on Ford (Mass Air) 5.0L and 5.8L fuel injection engines. This includes all wiring that is needed by the computer to run and control the fuel injection system.

Usually, the Computer, Fuse block and Relays can easily be mounted under the dash. Most of the wiring in the harness has been pre-terminated to the proper connector and all wire is rated at 125C and has been Ford color-coded.

These fuel system harnesses have been divided into three major groups:

ENGINE GROUP	Includes wiring for the fuel injectors, distributor, sensors, and constant power wire.
DASH GROUP	Includes ignition feed wire, STO and STI (self test) connectors, check-engine light, and the barometric pressure connector.
TAIL SECTION	Power wire for fuel pump and VSS.

2.0 ABOUT THESE INSTRUCTIONS

These instructions provide information for the installation of the 60510 Fuel Injection Wire Harness Kit. The contents of these instructions are divided into major **Sections**, as follows:

- 1.0 Introduction
- 2.0 About These Instructions
- 3.0 Tools Needed
- 4.0 Pre-Installation and Harness Routing Guidelines
- 5.0 General Installation Instructions
- 6.0 60510 & 60511 Fuel Injection Harness Kit
- 7.0 Start Up
- 8.0 Trouble Shooting Instructions and Trouble Codes

Sections are further divided into **Paragraphs** and **Steps**. Throughout, the **Figure** numbers refer to illustrations and the **Table** numbers refer to information in table form. These are located in or near the sections or paragraphs to which they correspond. Always pay careful attention to any *Notes* or any text labeled **CAUTION**.

3.0 TOOLS NEEDED

In addition to your regular tools, you will need, at least, the following:

Crimping Tool	<i>Note: Use a quality tool to avoid over-crimping.</i>
Wire Stripper	
Continuity Tester	Caution: Do <u>not</u> use a test light to test the computer or sensor wiring or you will damage the computer.
Electric Drill	
1-5/8" Hole saw	(for the rubber grommet in the firewall)

4.0 PRE-INSTALLATION AND HARNESS ROUTING GUIDELINES

The installation of your harness kit consists mainly of two parts:

- The physical routing, positioning, and securing of the harness, wire groups, and individual wires and connectors.
- The proper electrical connection of the individual circuits.

These two major tasks are not separate steps, but are integrated together. That is, you will route some wires and make some connections, route some more wires and make some more connections.

We cannot tell you how to physically route the harness in your vehicle. That depends a great deal upon the particular make of vehicle and to what extent you want to secure and conceal the harness. We do offer some general guidelines and routing practices starting in **Paragraph 4.3**, GENERAL installation instructions in **Section 5.0**, and precise instructions concerning the electrical connections you will have to make beginning in **Section 6.0**. To help you begin thinking through the installation of your wire harness, read the following sections:

4.1 You should get to know the particular engine that you are using:

- Ford Fuel Injection System with a mass airflow (MAF) sensor. The 60510 & 60511 harness will support the Mass Airflow (MAF) and the Thick Film Ignition (TFI) module in addition to the other wiring common to the fuel injection systems.

4.2 Painless recommends the use of the following parts. See **Table 4.1 on page 3**. These will meet all requirements and are compatible with the Painless harnesses. The following numbers given are Ford or Motorcraft part numbers. The main computer part numbers are REQUIRED for use with our harnesses.

Note: Calibration numbers. If the calibration is known, it is best and recommended that all part have matching calibration. This is for the best performance.

The computer part numbers shown in the compatible parts list in **Table 4.1** are required part numbers for that application. The use of any other computer may damage the computer, harness or both. Use of the wrong computer will almost certainly cause problems. The programming in the computer for a manual transmission is slightly different than that of an automatic. Please double check to be sure that you have the correct computer part number (it is shown as a service number on the computer itself). The rest of the part numbers shown are for your information only.

4.3 Familiarize yourself with the harness by locating each of the harness groups and by looking at the connectors on the wire ends.

4.4 Decide where and how the computer and sensors will be mounted. PPP wire harness kits are designed to mount both, under the dash or in the lower kick panel on the right side.

4.5 A good exercise is to lay out the wire harness on the floor beside your vehicle and identify all the connectors and wires. The harness must be routed from the inside of the vehicle out to the engine compartment.

4.6 You will want to route the harness through and around open areas. Inside edges provide extra protection from hazards and also provide places for tie wraps, clips and other support.

4.7 Route the harness away from sharp edges, exhaust pipes, and the hood, trunk, and door hinges.

- 4.8 Plan where harness supports will be located. Use a support approximately every 6 inches unless the harness routes under the floor carpet.
- 4.9 Allow enough slack in the harness at places where movement could possibly occur (body to frame, frame to engine, etc.).
- 4.10 The wires should be bundled into harness groups. Use tape, nylon ties or split loom.

60510 & 60511 FUEL INJECTION KIT		
Description	Ford	Motorcraft
Main Computer (auto transmission)	M-12071-G302 (Ford Racing)	
(manual transmission)	M-12071-F302 (Ford Racing)	
Thick Film Ignition module (TFI)	E6SZ-12A297-A	DY-504
Throttle Position Sensor	E6AF-9B989-CA	CX-1133
Barometric Absolute Pressure Sensor	E7EF-12A644-A2A	DY-530
Intake Air Temperature Sensor	F2DF-12A697-AA	DY-674
Fuel Pump Relay	87452 (Hella)	
EEC Power Relay.....	87452 (Hella)	
Engine Coolant Temperature Sensor	F2AF-12A648-AA	DY-681
Heated Exhaust Gas Oxygen Sensor (HEGO)	E7TF-9F472-AA	DY-605
Vehicle Speed Sensor	E3AZ-9E731-A	
E.G.R. Valve	E7PE-9H473-H2A	CX-1230A
E.G.R. Sensor	F2ZE-9G428-AA	CX-1464
E.G.R Valve Gasket		CG-697
EGR Vacuum Regulator (EVR)	E63Z-9J459-A	

Note: The main computer is from FORD RACING. Relays are from HELLA.
If you have a used computer take the time to call your local Ford Parts Dealer to verify you have the proper PCM. **If you know the calibration of your engine it is best to buy parts with the same code.**

Table 4.1 Compatible Parts (Main Computer comes with MAF sensor)

5.0 GENERAL INSTALLATION INSTRUCTIONS

CAUTION:

- **Do not disconnect the battery or the computer connector(s) while the ignition is on.**
- **Do not short any wire in this harness to ground (with the exception of labeled ground wires) or damage to the computer will result.**
- **Giving or receiving a jump-start may damage the computer.**
- **Do not use a test light when testing computer sensors or computer circuits. Damage to the computer will result!**
- **When routing the wires for the vehicle speed sensor (if used) make certain that they are at least 12 inches away from any ignition wiring (spark plug wires, etc.).**

Notes:

- **All of the adapters, listed in the manual, are included in the wiring kit. You should use or remove them depending on your particular application.**

- **Each connector in this harness is different and will not fit in the wrong place. NEVER FORCE ANY CONNECTOR.**
- **When connecting the plugs to the computer USE EXTREME CARE to make sure none of the pins in the computer are or have become bent.**
- **The timing connector for the ignition is near the computer.**
- **The fuel pump you are using MUST be rated at a minimum of 40 pounds PSI (per square inch), and 33 gallons GPH (gallons per hour)**
- **If you have headers you may have to relocate the H.E.G.O. sensor for proper clearance.**

Note: Install H.E.G.O's no more than three inches from your header to pipe flanges.

5.1 GROUNDING THE VEHICLE

A perfectly and beautifully wired automobile will nevertheless have problems if everything is not properly grounded. Don't go to the effort of installing a quality wire harness only to neglect proper grounding.

- 5.1.1** Connect a ground strap or cable (minimum of a 4-gauge wire) from the negative battery terminal to the automobile chassis (frame).
- 5.1.2** Connect a ground strap from the engine to the chassis (frame). **DO NOT RELY UPON THE ENGINE MOUNTS TO MAKE THIS CONNECTION.**
- 5.1.3** Connect a ground strap from the engine to the body.

5.2 ROUGH INSTALLATION

Caution: *Disconnect the power from your vehicle by removing the negative battery cable from the battery.*

Note: *Make no wire connections or permanent mounting of any kind at this time.*

- 5.2.1** Position the computer and sensors in their intended locations.
- 5.2.2** Drill a 1-5/8" hole for the firewall grommet near the computer for the engine group and tail section to pass through.
- 5.2.3** Route the engine group and tail section through the hole. Push the grommet (already installed on the harness) into the hole until it is seated.
- 5.2.4** Route the dash group over to the driver's side of the car.

5.3 HARNESS ATTACHMENT

Note: *Harness routing and shaping will be a time-consuming task. Taking your time will enhance the beauty of your installation. Please be patient and take your time.*

- 5.3.1** Permanently mount computer. You should mount the parts (sensors, relays, etc.) that will be used for your engine at this time. These parts will vary by application.
- 5.3.2** Mold harness groups to the contour of the dash, engine, frame, etc. Remember to route the harness away from sharp edges, exhaust pipes, hinges, and moving parts.
- 5.3.3** Attach harness groups to your automobile with clips or ties starting at the computer and working your way outward.

Note: *Do not tighten tie wraps or mounting devices at this time. Make all harness attachments LOOSELY.*

- 5.3.4** When used every 1-1/2" or so on the visible areas of the harness, plastic wire ties make a very attractive assembly. Otherwise, a tie installed in other areas every 6" or so will hold the wires in place securely. REMEMBER TO TAKE YOUR TIME.

5.4 TERMINAL INSTALLATION INSTRUCTIONS

Note: *In the following steps you will be making the circuit connections. Before you start, you should carefully read Sections 6.0 through 8.0, as applicable, and continually refer to the wire connection charts, **DOUBLE CHECKING** your length calculations before cutting any wire or making any connections. These directions are for the wires, which do not have a connector already, installed on them.*

- 5.4.1** Have all needed tools and connectors handy.
5.4.2 Select the correct terminal for the wire and application.
5.4.3 Determine the correct wire length and cut the wire. Remember to allow enough slack in the harness and wires at places where movement could possibly occur. **DOUBLE CHECK YOUR CALCULATIONS.**
5.4.4 Strip insulation away from wire. Strip only enough length necessary for the type of terminal you are using.

Note: *In the following step, make sure that the terminal is crimped with the proper die in the crimping tool. An improper crimp will not make a good connection. **DO NOT OVER CRIMP.***

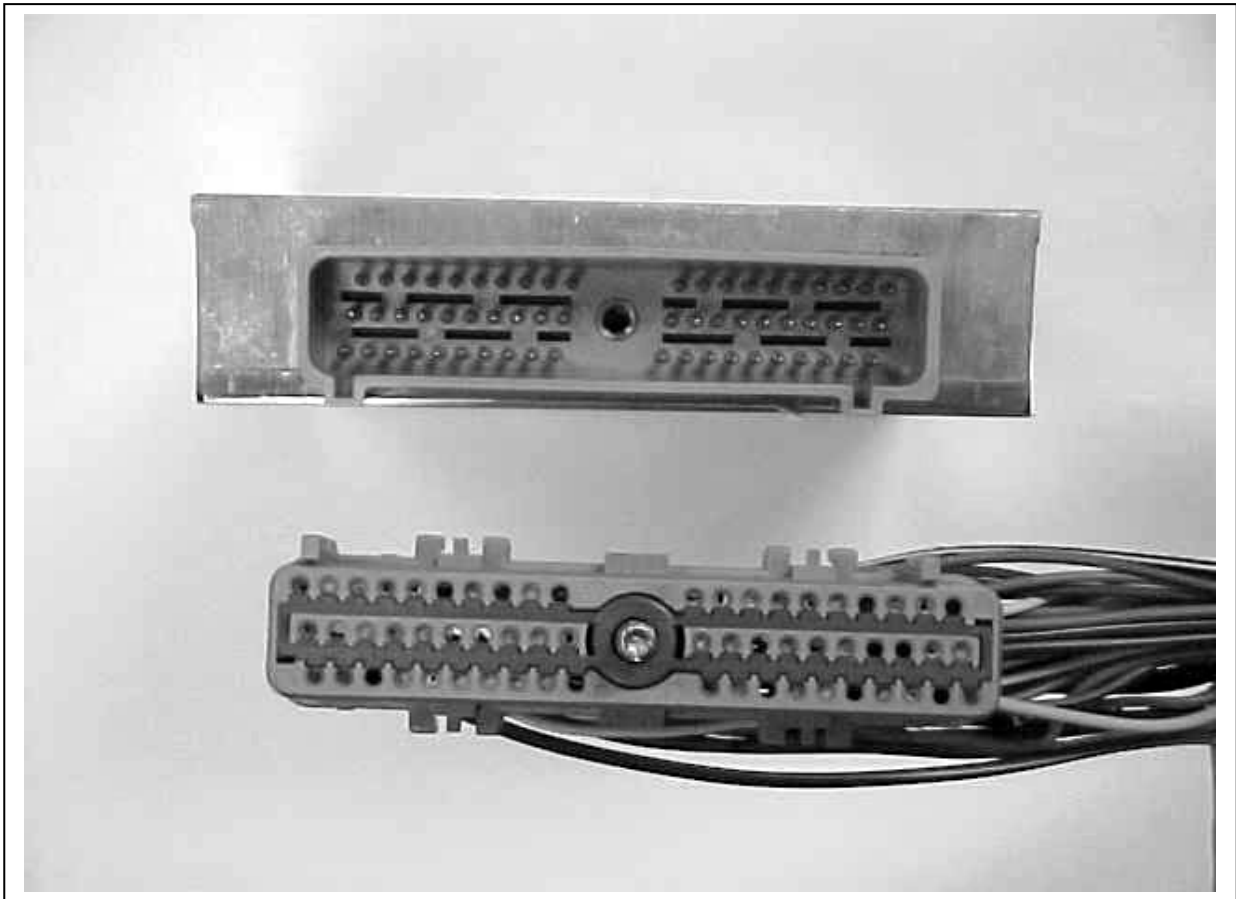

Figure 5.1 Computer & Harness Connector

- 5.4.5 Crimp the terminal onto the wire.
- 5.4.6 Connecting the wires and connectors throughout the harness is a repeating process. Make sure that each wire is first properly routed and then attach. DO NOT ATTACH THEN ROUTE AFTERWARD.
- 5.4.7 When all wires are attached, tighten the mounts and ties to secure harness permanently.
- 5.4.8 Attach the connectors to the computer BEING CAREFUL NOT TO BEND ANY PINS.
- 5.4.9 **Only after all connections have been made** throughout the harness, connect the battery to the vehicle.

CAUTION: *Be sure the ignition is off when you reconnect the battery or you will damage the computer.*

6.0 FORD 5.0 WIRING HARNESS INSTALLATION INSTRUCTIONS

(The Painless harness and systems are designed around the 1993 Ford Mustang)

6.1 CONTENTS OF THE 60510 & 60511 WIRE HARNESS KIT

Take inventory to see that you have everything you are supposed to have in this kit. If anything is missing, go to the dealer where you obtained the kit or contact Painless Performance at (817) 244-6898. The kit should contain the following items:

- The main wire harness with the connectors already on the ends of most of the wires.
- Thick Film Ignition Adapter.
- Fuel Injection Installation Instructions P/N 90510 (this booklet).

6.2 DASH SECTION INSTALLATION

Note: *If you have not already done so, read Sections 4.0 and 5.0 of these instructions and think through the installation of the harness before securing or cutting any wires.*

The wires in this group consist of the STO and STI (self test) connectors, the check engine light and bracket and four other wires.

Note: *You will need to connect the check engine light wires to their mates in the wire harness.*

CAUTION: *Do not make any connections while the computer is plugged into the harness.*

Note: *Wire color (example: Blk/Wht) is one wire with a stripe. The second color (the stripe) may not be bold. Observe all two-color wires closely.*

Find a suitable location to mount the check engine light bracket so that it will allow you to see the check engine light while driving. After mounting the light bracket install the light into bracket.

Note: *Install bracket before installing the light.*

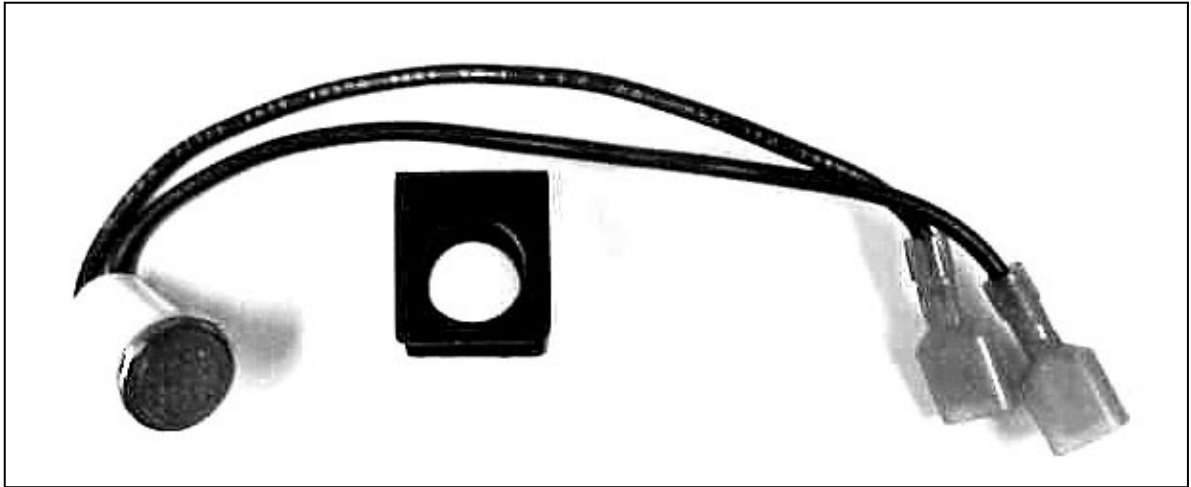

Figure 6.1 Check Engine Light

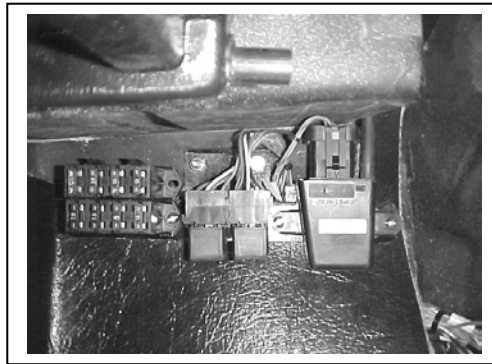

Figure 6.2 (BAP) Barometric Pressure Switch



Figure 6.3 (TPS) Throttle Position Sensor



Figure 6.4 (IAT) Intake Air Temperature - right & (ECT) Engine Coolant Temperature - left

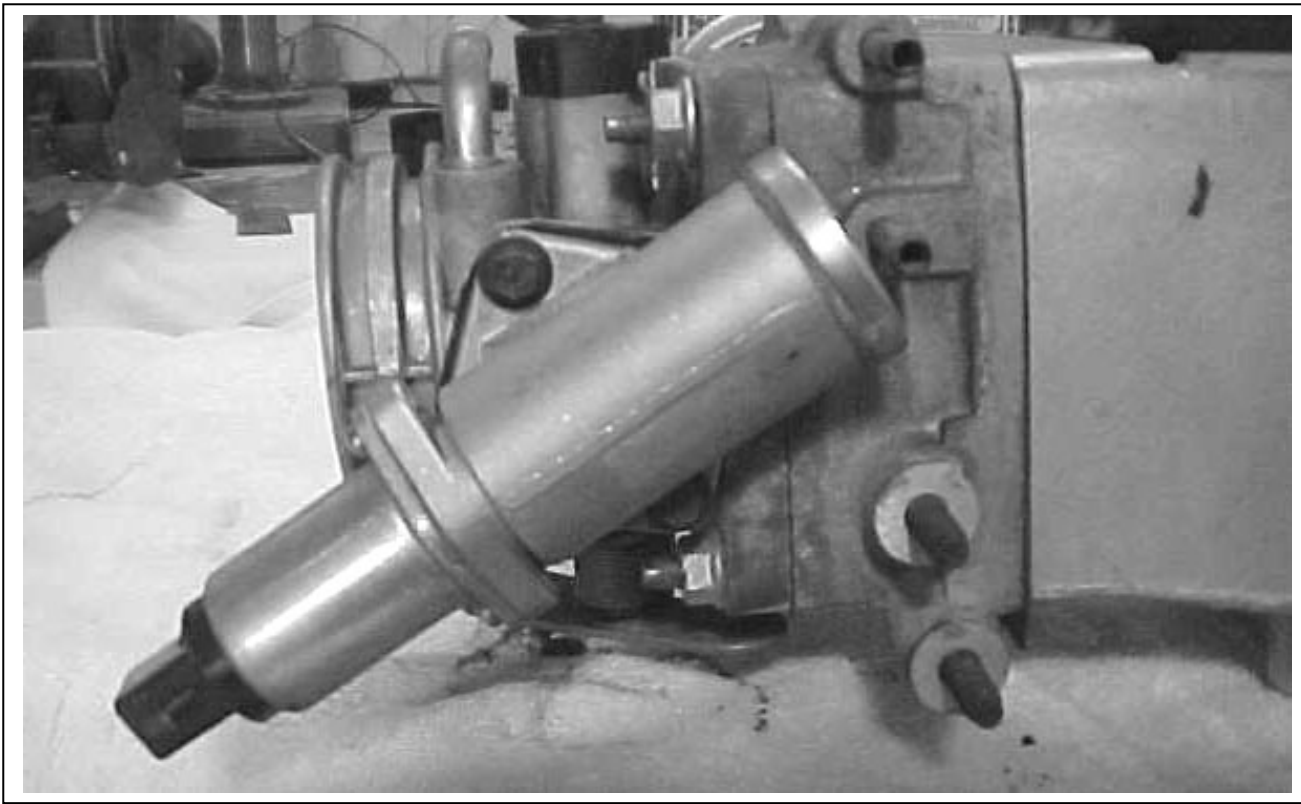

Figure 6.5 (IAC) Idle Air Control Valve

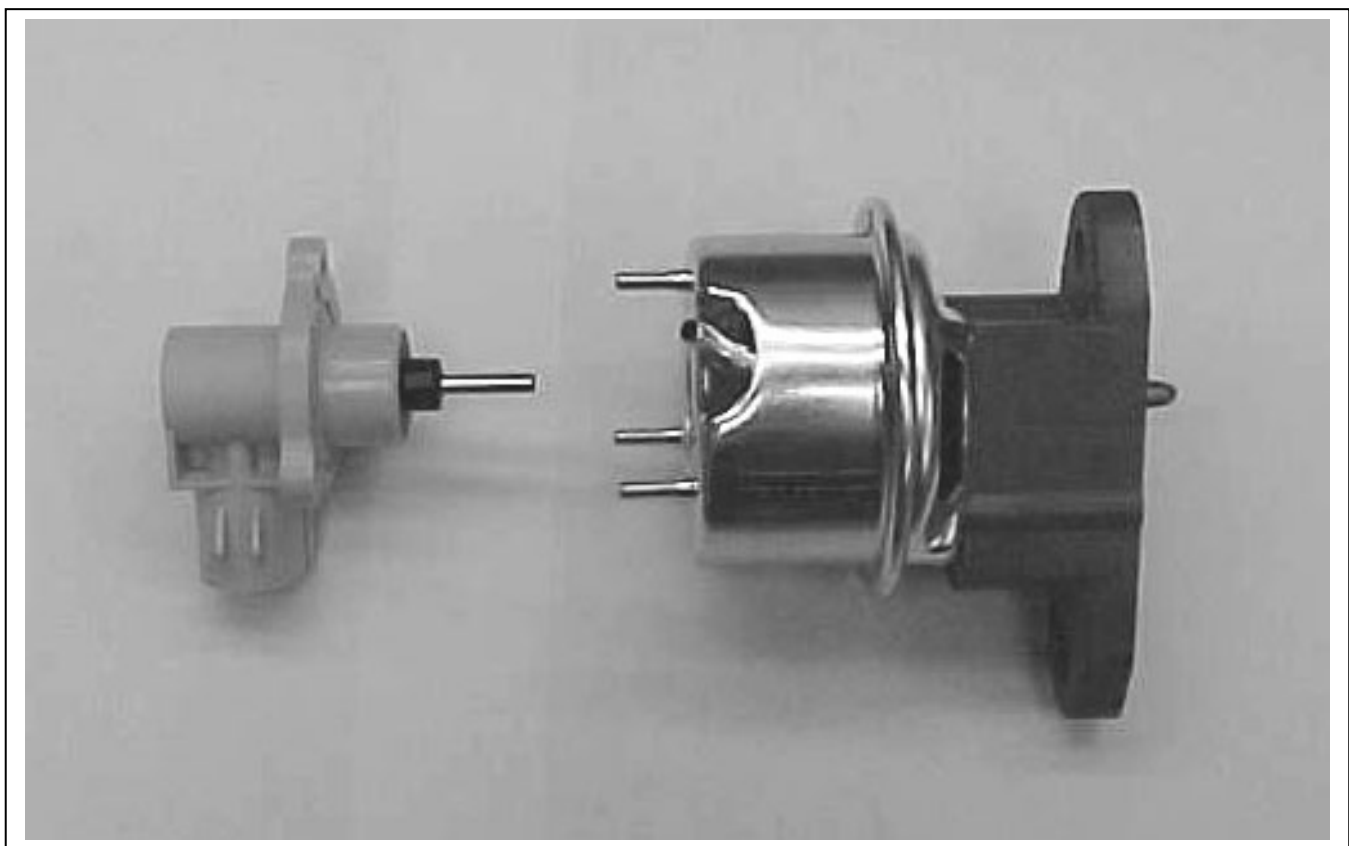

Figure 6.6 (EGR) Exhaust Gas Recirculation Valve

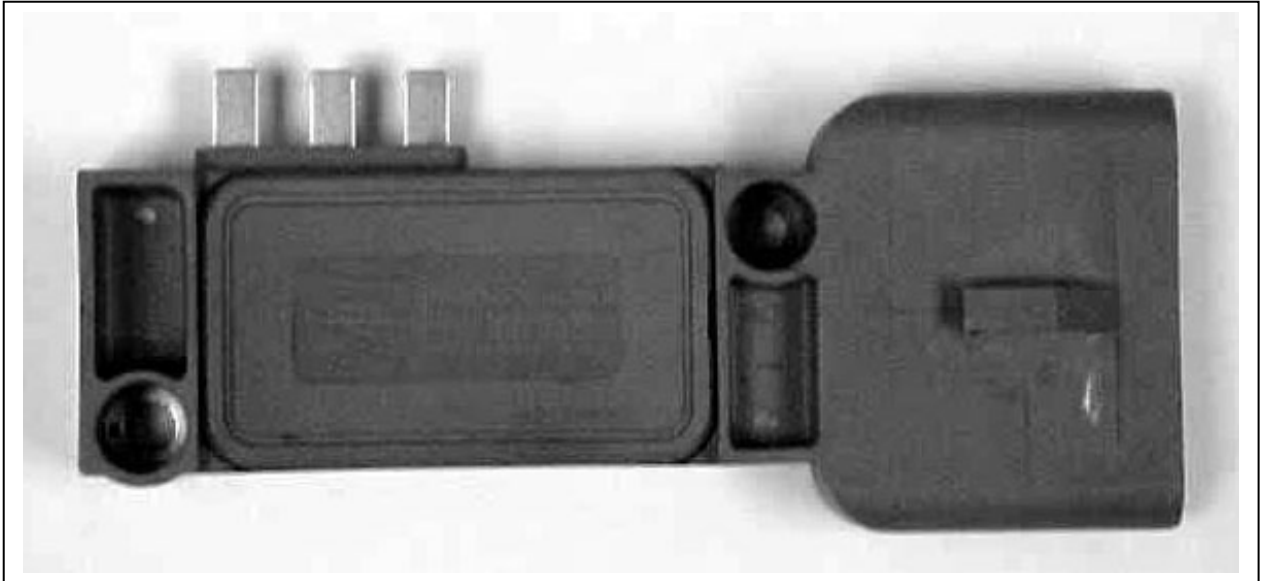

Figure 6.7 (TFI) Thick Film Ignition Module

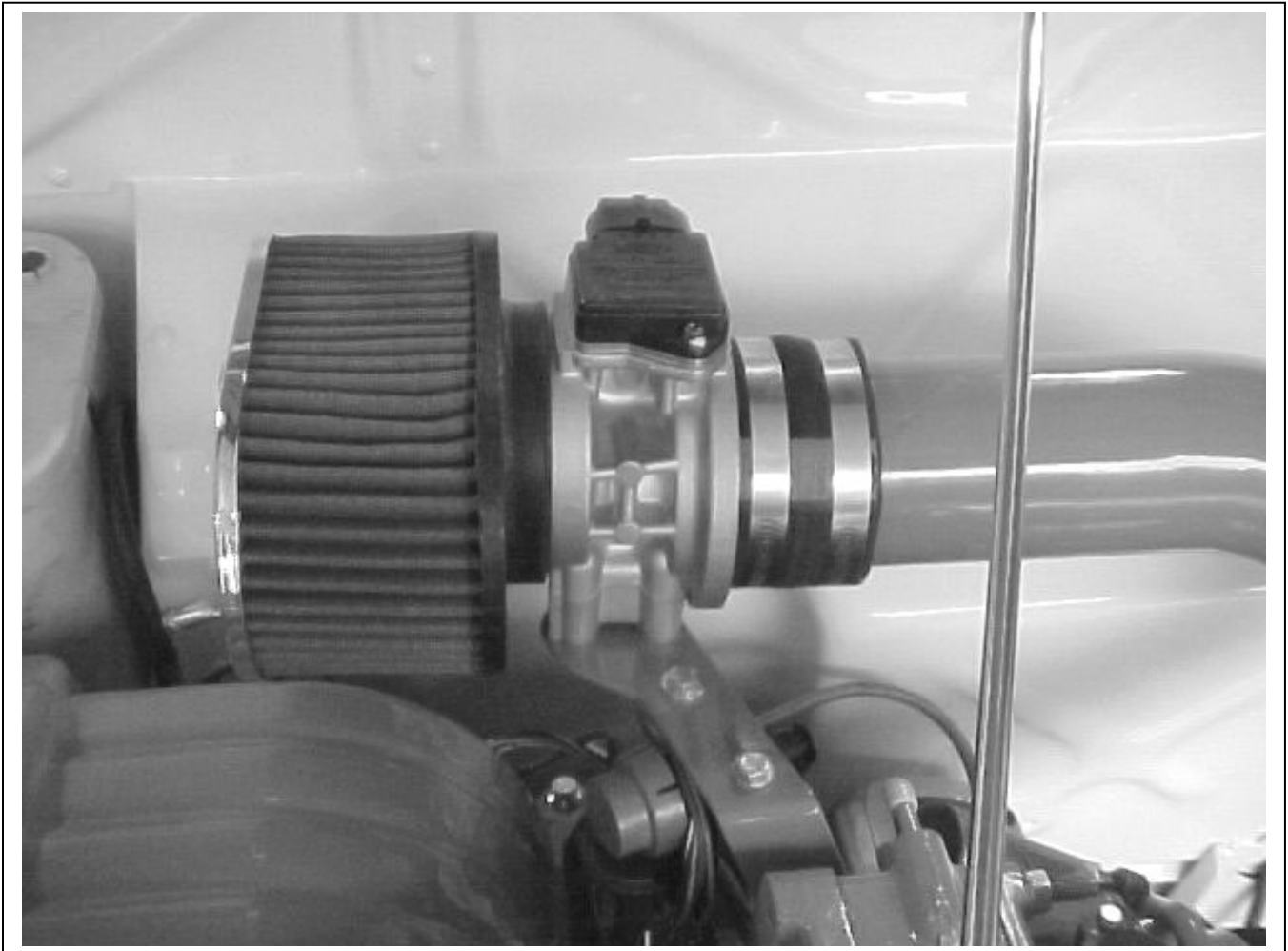

Figure 6.8 (MAF) Mass Air Flow Sensor w/air filter

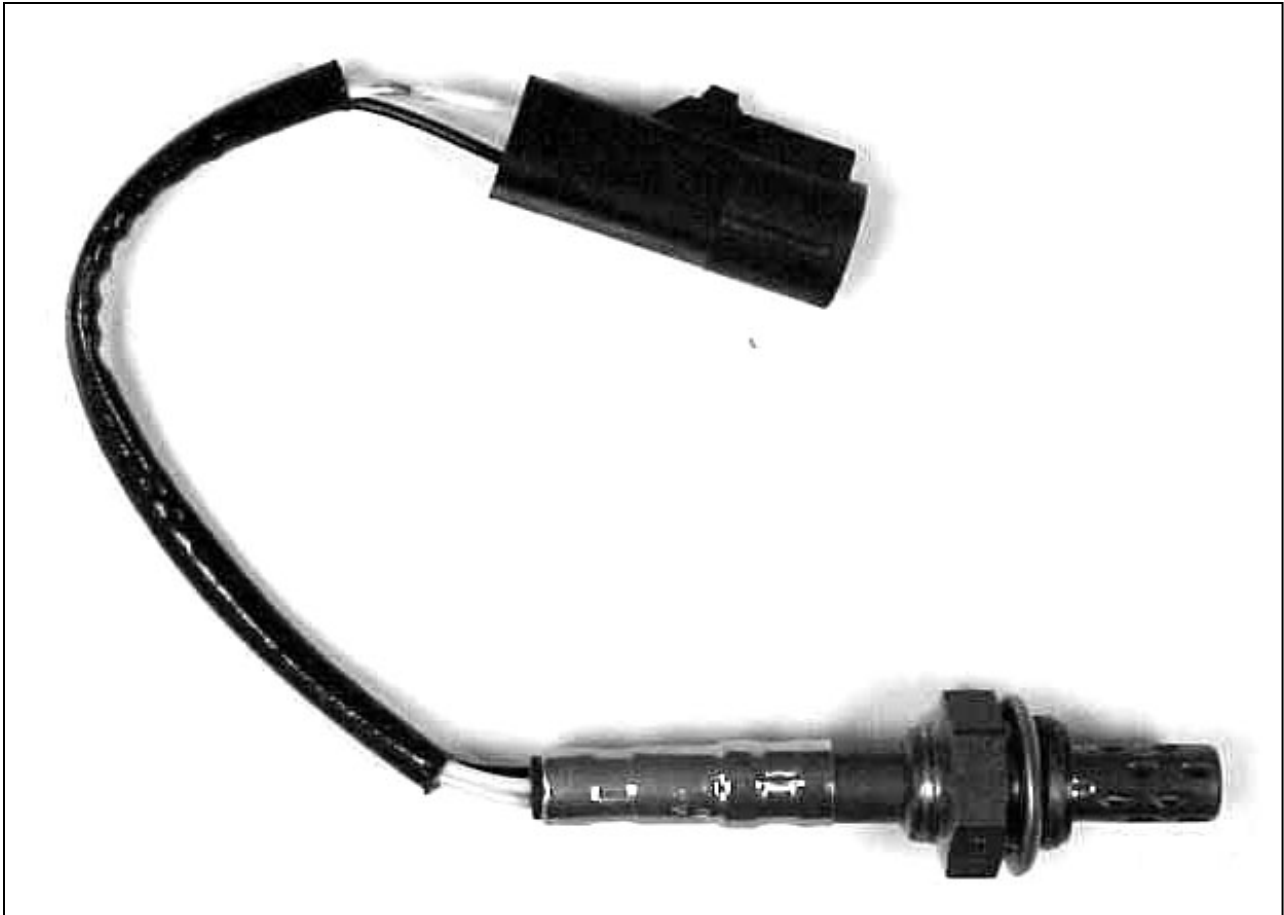

Figure 6.9 (HEGO) Heated Oxygen Sensor (Note: left and right are the same)

Locate the RED/LT.GRN wires and attach them to the chassis fuse panel or the ignition switch. **POWER IS REQUIRED WHEN THE KEY IS IN THE RUN AND START POSITION.** This is the power wire for the computer and relays.

Caution: *Do not connect these wires using directions from different instructions. You may damage the computer.*

6.3 ENGINE GROUP INSTALLATION

The engine group is designed to be separated into left side (driver), right side (passenger), and a Mass Air Flow section. Each side is tie-wrapped separately, **but not labeled.**

Note: *The plenum cannot be installed until harness has been installed.*

Note: *If you have not already done so, separate the tail section from the engine group and place it out of the way.*

- A. Locate the Orange **EEC GROUND** wire in the harness that end in a single ring terminal. Ground this wire to the engine. An intake manifold bolt is the proper place. This wire is for the ground for the ignition. The engine will not run if not attached properly.

- B. Starting at the rear of the engine, using **Table 6.2**, and the **Figures** in **Section 6.3**, begin attaching the connectors to their proper places and THEN secure the harness to the engine when ready.
- C. Locate the yellow wire labeled **STARTER RELAY** and route it to the starter relay. Attach this wire to the BATTERY post on the relay.

Color	#Positions In Connector	Labeled	Connect To
Grn/Ylw(1), Lt.Blu/Orn, Ylw, Red	5	Fuel Pump Relay	Fuel Pump Relay
Blk/Wht, Red/Lt.Grn, Red or Ylw	4	EEC Power Relay	EEC Power Relay
Brn/Wht, Gry/Red, Lt.Grn/Blk	3	BAP (2)	Barometric Pressure Sensor
Red/Lt.Grn	2 wires	Ignition	Ignition
Tan/Ylw	1 wire	TACH	Tachometer (optional)
Blk/Wht, Blk	2 wires w/ring	EEC Ground	A good grounding source
NOTES:			
1. On Striped wires (example: Blk/Wht), the second color (stripe) may not be bold. Observe two-color wires closely.			
2. BAP can also be mounted under the hood.			

Table 6.1 Dash Section

Wire Colors	# Positions In Connector	Labeled	Connect to
Red/Lt.Grn, Tan/Ylw	3	COIL	Coil
Gry/Red, Brn/Wht Brn/Lt.Grn	2	EGR	Exhaust Gas Recirculation Valve
Red, Wht/Blu	2	IAC	Idle Air Control Valve
Gry/Red, Gry/Wht Brn/Wht	3	TPS	Throttle Position Sensor
Lt.Grn/Red, Gry/Red	2	ECT	Engine Coolant Temp Sensor
Red (2), Tan, Lt.Blu, Wht, Lt.Grn/Orn, Tan/Red, Brn/Ylw, Brn/Lt.Grn, Tan/Blk	8 connectors 2 pos. each	INJ	Fuel Injectors
Ylw	---	---	Starter Relay (Large Battery Terminal)
Brn/Pnk, Red	2	EVR	EGR Vacuum Regulator
Red/Blk, Gry/Ylw, Blk/Wht	4	Right HEGO (1)	Heated Exhaust Gas Oxygen Sensor
Gry/Blu, Gry/Ylw, Blk/Wht	4	Left HEGO (1)	Heated Exhaust Gas Oxygen Sensor
Gry, Gry/Red	2	IAT	Intake Air Temp Sensor
Red, Blk/Wht, Lt.Blu/Red, Tan/Blu	4	MAF	Mass Air Flow
Orn/Red, Pnk, Tan/Ylw Gry/Org, Red/Lt.Grn	6	TFI	Thick Film Ignition
NOTES:			
1. If you have headers you may have to relocate the HEGO sensors for proper clearance. Painless also has bungs for your HEGO sensors, Painless part number 60406.			
2. Each injector connector has a Red/Wht or Red/Ylw wire.			

Table 6.2 Engine Section



Figure 6.10 EGR Vacuum Regulator Solenoid (EVR)

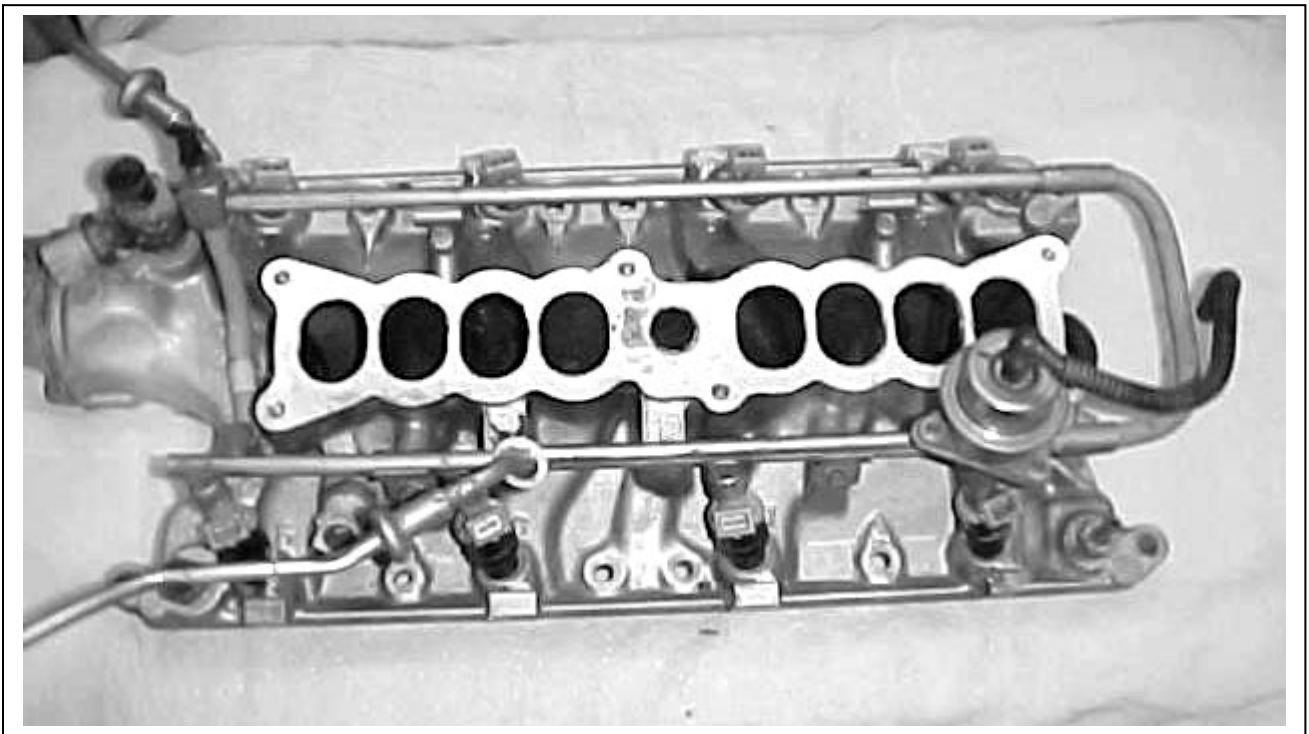

Figure 6.11 Intake (with plenum removed for harness installation)

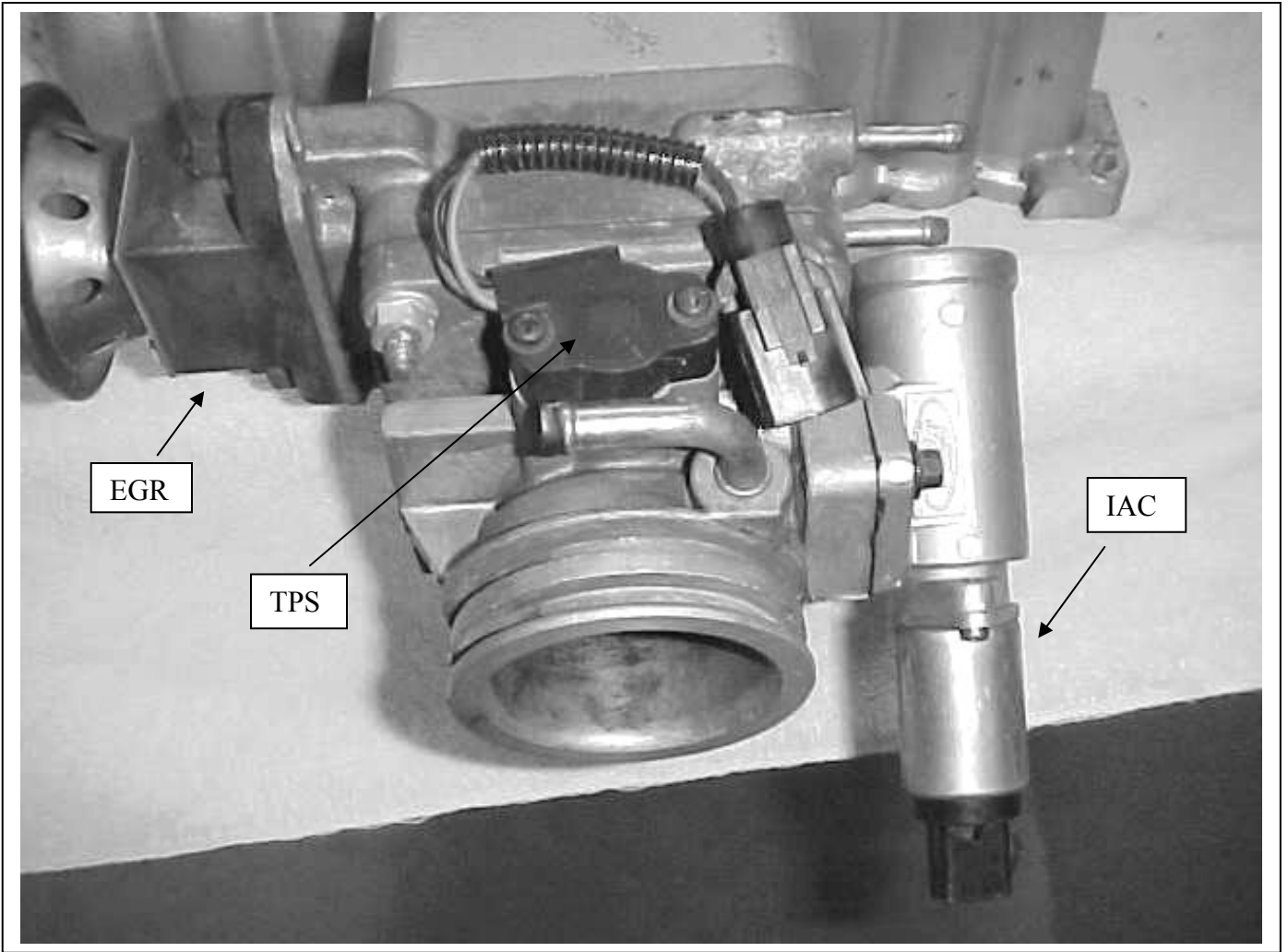

Figure 6.12 Locations of EGR, TPS & IAC (these are mounted on the plenum)

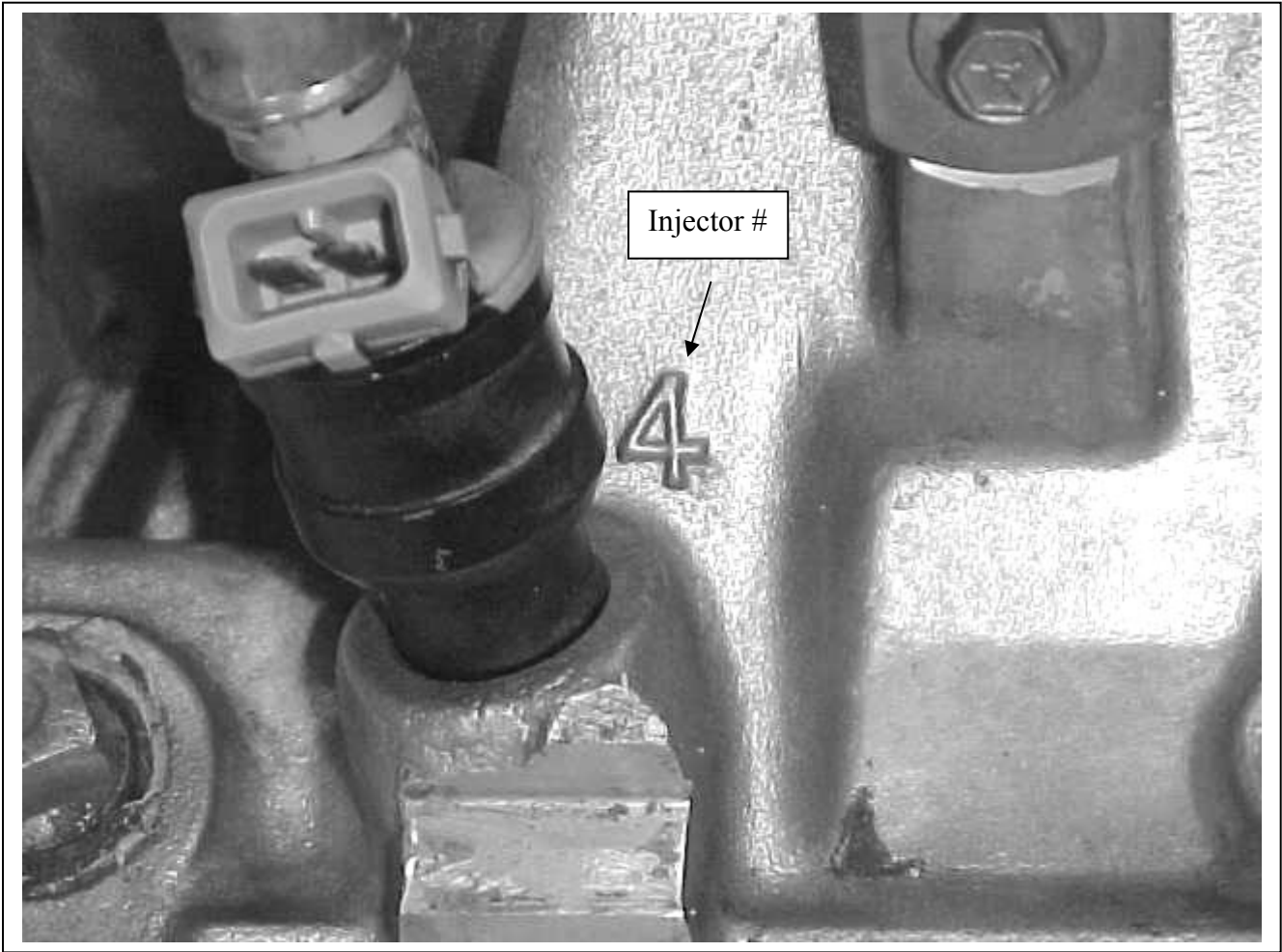

Figure 6.13 Injectors (numbered on stock intake)

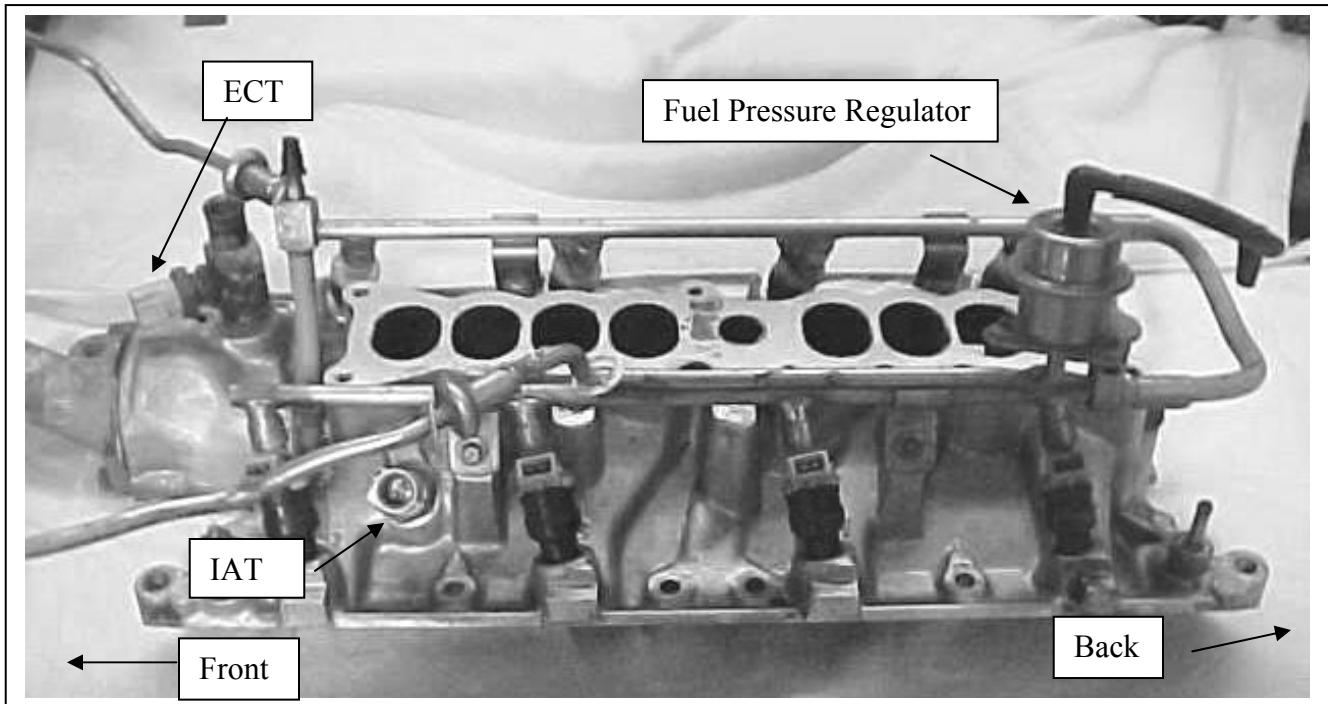

Figure 6.14 Location of IAT & ECT

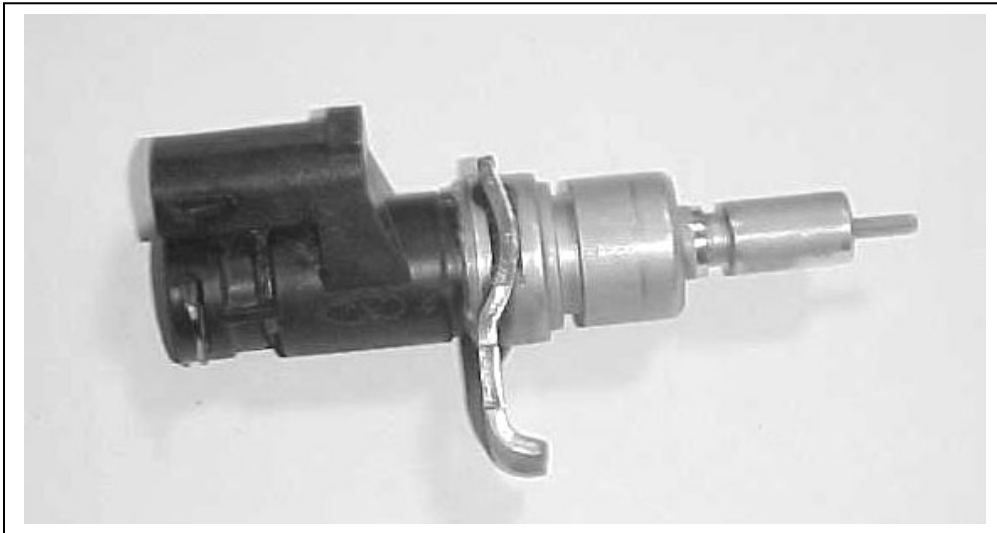

Figure 6.15 VSS Vehicle Speed Sensor



Figure 6.16 Calibration Code

6.4 TAIL SECTION INSTALLATION

- A.** Locate the tail section that you earlier separated from the engine group. Begin routing it towards the rear of the vehicle. Be sure to avoid all sharp edges, moving or hot parts, or anything else that may damage the harness.
- B.** If you ARE using the VSS, route the 2-position connector to the transmission and attach it to the sensor, **Figure 6.15**.
- C.** If you ARE NOT using the VSS, tape up the connector and store it in the harness.
- D.** Take the long GRN/YLW wire and route it to the fuel pump. This is the power wire for the fuel pump.

Wire Colors	# of Positions	Labeled	Connect to
Grn/Ylw	1	Fuel Pump	Fuel Pump
Gry/Blk, Pnk/Orn	2	VSS	Vehicle Speed Sensor

Table 6.3 Tail Section



Figure 6.17 Barometric Pressure Switch (BAP)

7.0 FORD 5.0 START UP

- 7.1 Install the 60 position E.E.C connector into your E.E.C. your computer. Starting the bolt by hand. Once started use a 10mm socket to tighten it the rest of the way. **DO NOT OVER TIGHTEN OR FORCE INTO PLACE.**
- 7.2 The fuel system must be pressurized. This is done by turn the key on and off several times.

Note: Inspect your fuel lines for leaks. From the tank to the engine.

- 7.3 Start your engine and listen for noises that would indicate a problem. While listening inspect your engine for fluid leaks.
- 7.4 You are now ready to set your initial engine timing.
 - 7.4.1 You must unplug the **SPOUT** connector located near the computer.
 - 7.4.2 Loosen your distributor and set your initial timing to the factory setting of 10° BTDC.
 - 7.4.3 Tighten the distributor back down and check timing. Shut off engine.
 - 7.4.4 Plug the **SPOUT** connector back together and restart the engine. The timing should advance at this time.
- 7.5 Check your H.E.G.O bungs for leaks while your vehicle is still running.

8.0 TROUBLE SHOOTING INSTRUCTIONS

If you are having trouble with your engine running badly or not running at all, first perform basic trouble shooting (checking for faulty connections, spark, timing, fuel pressure, etc.) then see if The computer has stored a trouble code in its memory.

8.1 THE "CHECK ENGINE" LIGHT

Normally, the "check engine" light should come on when the ignition is initially turned on, then go out a few moments after the engine starts running. If it reappears, or stays on while the engine is running, the computer has detected a problem and a trouble code has been set.

- 8.1.1 The computer identifies particular trouble codes by flashing the "check engine" light in a certain way. The codes are read by counting the flashes:
 - A. The first digit (the "tens" digit) of the code is flashed quickly, followed by a brief pause, then the second digit (or "ones" digit) is flashed, followed by a longer pause. For example, three (3) quick flashes followed by a brief pause followed by two (2) flashes indicates code 32.
 - B. The code will repeat itself three (3) times. The next code, if any, will be displayed in the same manner.

Note: When you access the codes from the computer a code 11 (one flash followed by one flash) will first be displayed. THIS DOES NOT INDICATE A PROBLEM. Code 11 will be flashed 3 times, followed by the particular trouble codes, if any. If the computer merely flashes code 11 there are no trouble codes stored. Code 11 means the system passed.

8.2 RETRIEVING TROUBLE CODES FROM THE COMPUTER KEY ON ENGINE OFF (KOEO)

8.2.1 Before you can perform this test you need to start your engine and allow it to run till you reach operating temperature. This is done so the H.E.G.O. sensors are warm.

8.2.2 In order to retrieve the trouble codes stored in the computer, locate the Self-Test connectors (STO and STI) (installed and connected in **Paragraph 6.2.1**). Take the STI connector and jumper it over to the STO connector. (See **Figure 8.1**)

Once you have done this turn the key to the on position. **Do not start vehicle. Do not press on the accelerator.**

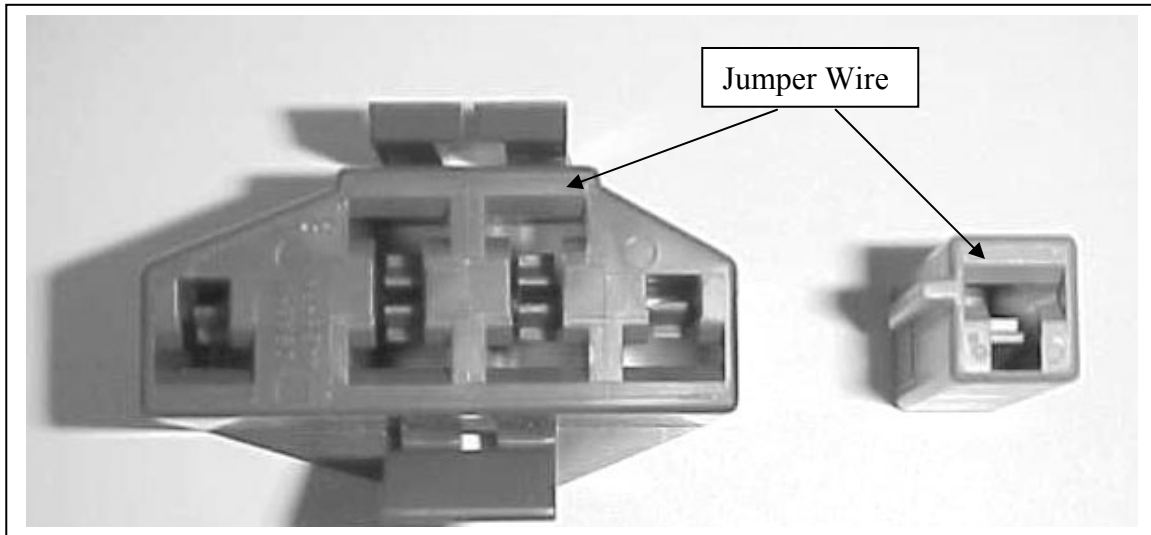

Figure 8.1 STO & STI Self-Test Connectors

8.2.3 After you have read any codes (remember the normal code 11), write them down for reference. Remove the jumper from the connectors. Turn key off. This procedure will take a few minutes. **Do not rush.**

8.2.4 Take the codes one at a time and match them to the codes in **Section 8.4**. This will tell you in which circuit the computer has detected a problem with.

Note: ***A code indicates a problem in a specific circuit, NOT THAT A PARTICULAR PART IS BAD.***

8.2.5 Before taking more extensive corrective actions for any trouble code, make sure that all connections on the indicated circuit, INCLUDING THE COMPUTER, are clean and tight. Inspect the wiring in the circuit for any broken, shorted, or exposed wires. Finally, insure all ground wires are clean and secure.

8.2.6 If you are getting a code from your computer and need to clear the code, other than code 11, after you have replaced a part, readjusted a part, etc. You can do this by making sure the ignition is off and then disconnecting the negative battery cable for a minimum of two minutes. After the two minutes are up then you simply reconnect the negative battery cable and recheck the system for codes.

8.3 **ENGINE RUNNING (ER)**

You will need to start and run your engine for several minutes, or until you have reached a normal operating temperature. As in KOEO test this is done to warm up the H.E.G.O sensors.

1. Turn off your engine and wait 10 to 15 seconds.
2. Jumper the STO and STI as described in the KOEO test.
3. Start your engine and read your codes. Match them to the codes in **Section 8.4**.
4. Once your finished Turn off your engine and remove the jumper.

8.4 **EEC-IV Diagnostic Trouble Codes and Definitions**

11	orc	System pass
12	r	Cannot control RPM during KOER Self-Test high rpm check (KEY ON ENGINE RUNNING)
13	r	Cannot control RPM during KOER Self-Test low rpm check
14	c	PIP circuit failure (PROFILE IGNITION PICKUP)
15	o	PCM Read Only Memory (ROM) test failed
15	c	PCM Keep Alive Memory (KAM) test failed
16	r	Rpm too low to perform HO2S test
18	r	SPOUT circuit open
18	c	IDM circuit failure/SPOUT circuit grounded
19	o	Failure in PCM internal voltage
21	or	ECT out of Self-Test range
22	orc	MAP/BARO out of Self-Test range
23	or	TPS out of Self-Test range
24	or	IAT out of Self-test range
26	or	MAF out of Self-Test range
29	c	Insufficient input from Vehicle Speed Sensor (VSS)
31	orc	EVP circuit below minimum voltage
32	orc	EVP voltage below closed limit
33	rc	EGR valve opening not detected
34	orc	EVP voltage above closed limit
35	orc	EVP circuit above maximum voltage
41	r	HO2S circuit indicates system lean (Right HO2S)
41	c	No HO2S switch detected (Right HO2S)
42	r	HO2S circuit indicates system rich (Right HO2S)
51	oc	ECT indicated -40°C (-40°F)/ circuit open
53	oc	TPS circuit above maximum voltage
54	oc	IAT indicated -40°C (-40°F)/circuit open
56	oc	MAF circuit above maximum voltage
61	oc	ECT indicated 123°C (254°F)/ circuit grounded
63	oc	TPS circuit below minimum voltage
64	oc	IAT indicated 123°C (254° F)/ circuit grounded
66	c	MAF circuit below minimum voltage
84	o	EGR Vacuum Regulator (EVR) circuit failure
87	oc	Fuel pump primary circuit failure
91	r	HO2S circuit indicates system lean (Left HO2S)
91	c	No HO2S switching detected (Left Ho2s)
92	r	HO2S circuit indicates system rich (Left HO2S)
98	r	Head fault is present-FMEM mode (Failure Mode Effects Management)
No	DTC'S	Unable to initiate Self-Test or unable to output DTC's

DTC's not listed will not be applicable to this system

Key: o= Key On Engine Off, r = Engine Running, c = Continuous Memory

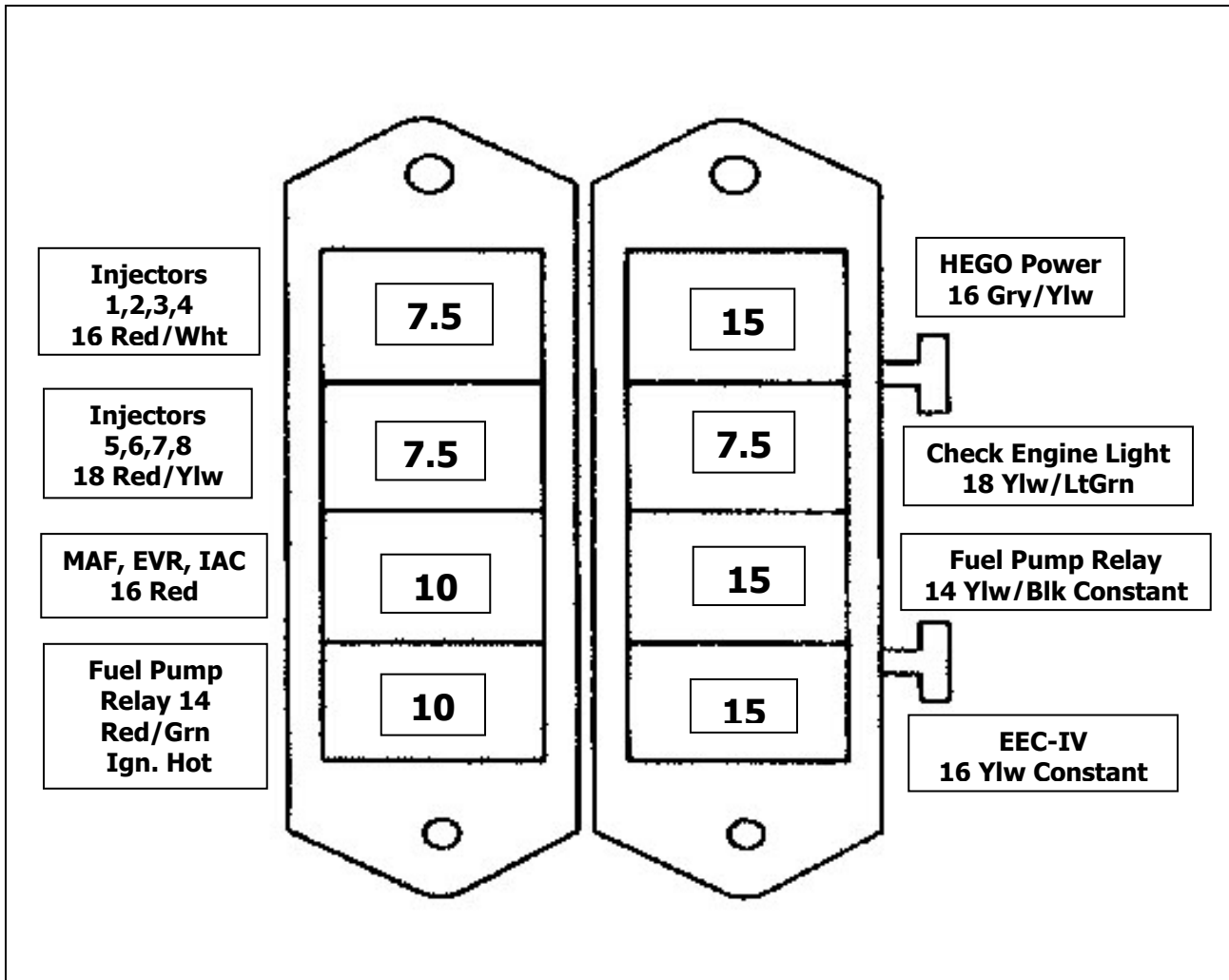

Figure 8.2 Fuse Location

8.5 WHEN TO CALL PERFECT PERFORMANCE PRODUCTS' TECH LINE

- 8.5.1** These harness kits have been built with the highest regard to strict quality control. Before calling us please double check all connections and perform normal basic trouble- shooting (fuel pressure, timing, ignition system, etc.).
- 8.5.2** If you have any questions concerning the installation of this harness or are having trouble in general, feel free to call PPP's tech line at (817) 560-TECH. Calls are answered from 8 am to 5 pm central time, Monday through Friday, except holidays. Please leave a message if you are unable to reach us and we will return your call as soon as possible.

E-mail: tech@painlessperformance.com

Web: www.painlessperformance.com

NOTES