

**KL700 7 channel system**  
**KL1000 10 channel system**  
**KL1600 16 channel system**  
**KL1800 18 channel system**

**CODE LEARNING**

Power ON, Parking lights (CH18 yellow wire) will flash 1 time to enter code learning mode. Press any button on the remote transmitter within 4 seconds. Parking lights will flash 2 times. If over 4 seconds, the system will exit code learning mode automatically. Up to 4 transmitters can be learned per module.

**DIP SWITCH SETTINGS**

Autoloc's KL700-KL1800 units offer several programmable features in order to customize your remote system. The KL700-KL1800 come set from the factory with all dip switch settings in the ON position. To change a setting:

1. Slide the dip switch to the desired position.
2. Press button #1 on the remote.
3. Press button #2 on the remote.
4. Press button #1 on the remote again.

**DIP SWITCH 1** (Channel 1- 9 Outputs)

ON: Channels 1-9 have pulsed outputs. When selected the output will pulse for 1 second.  
 OFF: Channels 1-9 have constant outputs. When selected the output will remain on for as long as you hold down the transmitter button.

**DIP SWITCH 2** (Channel 10-18 Outputs)

ON: Channels 10-16 have pulsed outputs. When selected the output will pulse for 1 second.  
 OFF: Channels 10-16 have constant outputs. When selected the output will remain on for as long as you hold down the transmitter button.

**DIP SWITCH 3** (Shaved Door Handle Safety Mode)

ON: When the Ignition is turned on channel 1&2 become inactive.  
 OFF: Channels 1&2 are active all the time.

**DIP SWITCH 4** (Channel 9-10 Latching Outputs)

ON: Channels 9-10 have latching outputs. Once selected, they will stay on until selected again.  
 OFF: Channels 9-10 have standard outputs.

**DIP SWITCH 5** (Channel 1&2 Shaved Door Handle Mode)

ON: Shaved Door Handle Mode Activated for Channels 1&2. The selected channel (1 or 2) will pulse 3 consecutive 1second pulses, per each push of the remote.  
 OFF: Shaved Door Handle Mode Inactivated.

**IMPORTANT NOTICE:** Upon completion of installation, you may have extra unused wires on the wiring harness. Do not be concerned. These wires are used for features available on other models.

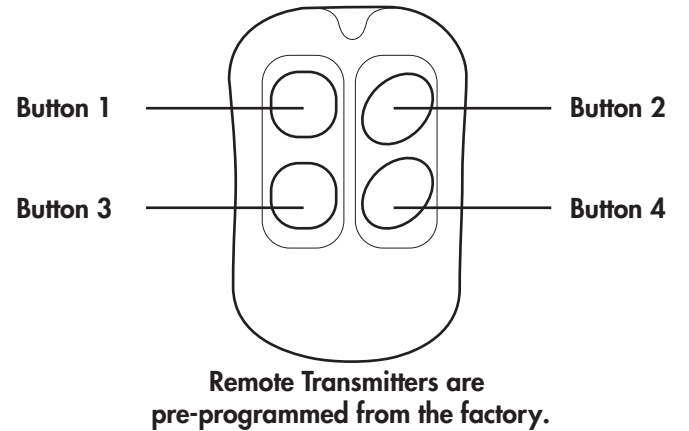

**NORMAL OPERATION**

Channel 1: Push Button 1  
 Channel 2: Push Button 2

Channels 3-18: Simply press button 3 on the remote transmitter the channel you desire, then push button 4 to send that selected channel.

**EXAMPLE:** To access channel 5, push button 3 of the remote transmitter 5 times. Your parking lights will flash after each push for confirmation. Now push button 4 of the remote transmitter to activate channel 5.

**NOTE:** You may also press and hold button 3 on the remote and count the number of times your parking lights flash. This number will equal the channel selected. Then push button 4 of the remote transmitter to activate that channel.

**NEW MULTIPLE BUTTON OPERATION**

**NEW FEATURE:** Remove jumper 6 for multiple button operation.

- Button 1 = Channel 1 output
- Button 2 = Channel 2 output
- Button 3 for 2 sec = Channel 3 output
- Button 4 for 2 sec = Channel 4 output
- Button 1 & 2 = Channel 5 output
- Button 1 & 3 = Channel 6 output
- Button 1 & 4 = Channel 7 output
- Button 2 & 3 = Channel 8 output
- Button 2 & 4 = Channel 9 output
- Button 3 & 4 = Channel 10 output
- Push Button 4 Twice then Button 1 = Channel 11 output
- Push Button 4 Twice then Button 2 = Channel 12 output
- Push Button 4 Twice then Button 3 = Channel 13 output
- Push Button 3 Twice then Button 1 = Channel 14 output
- Push Button 3 Twice then Button 2 = Channel 15 output
- Push Button 3 Twice then Button 4 = Channel 16 output
- Push Button 4, Push Button 3 then Button 1 = Channel 17 output
- Push Button 4, Push Button 3 then Button 2 = Channel 18 output

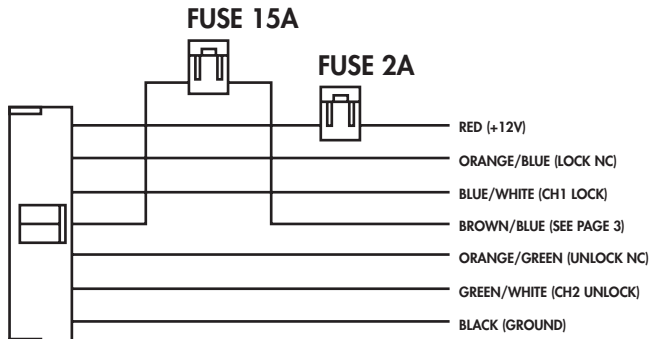
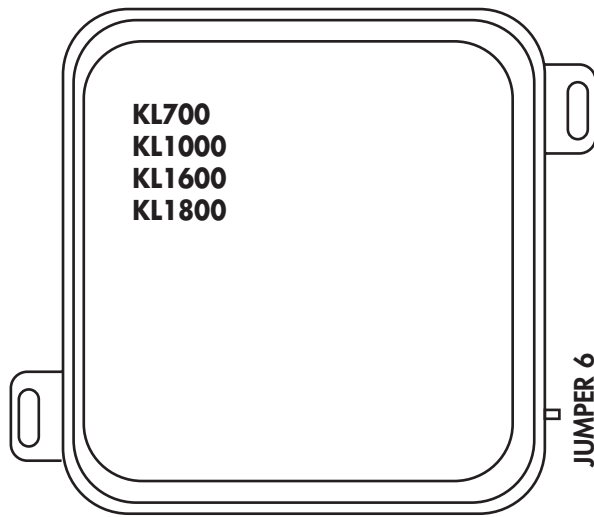

**IMPORTANT NOTICE:** Upon completion of installation, you may have extra unused wires on the wiring harness. Do not be concerned. These wires are used for features available on other models.

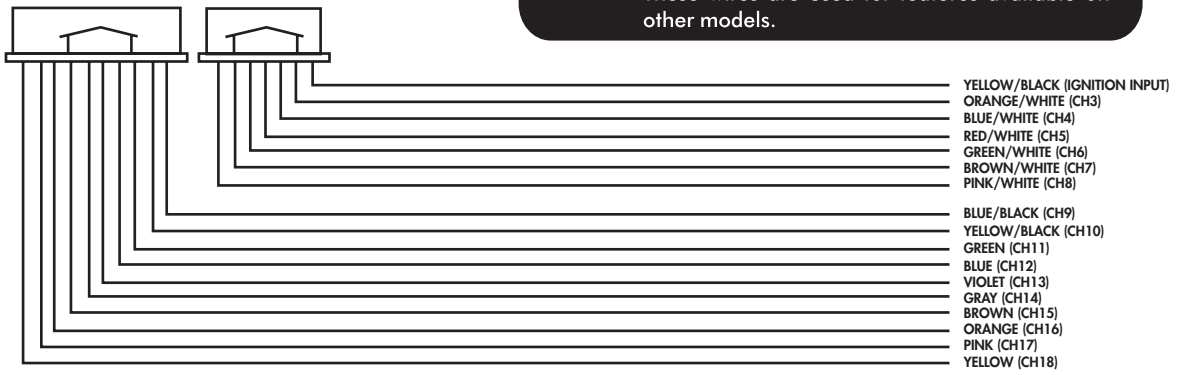

**POWER WINDOWS & MOTORS**

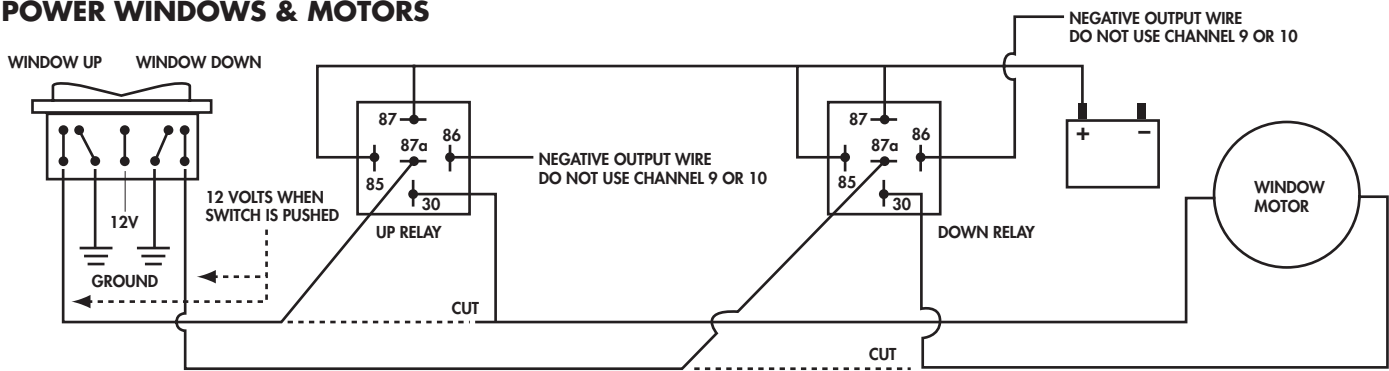

**ALARM REMOTES, GARAGE DOOR OPENERS, ETC.**

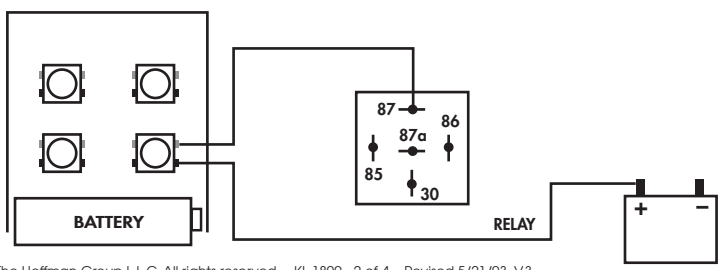

1. Disassemble the remote to gain access to the circuit board.
2. Locate the button to be triggered by the keyless entry system. The button will have an input, and an output. To test, use a wire to jump the connections of the button.
3. Connect the INPUT wire to terminal 30 of the relay.
4. Connect the OUTPUT wire to terminal 87 of the relay.
5. Connect terminal 86 to constant 12 Volts.
6. Connect terminal 85 to the keyless entry unit's channel wire.
7. Reassemble the remote and place it under the dash.

# WIRING DIAGRAMS

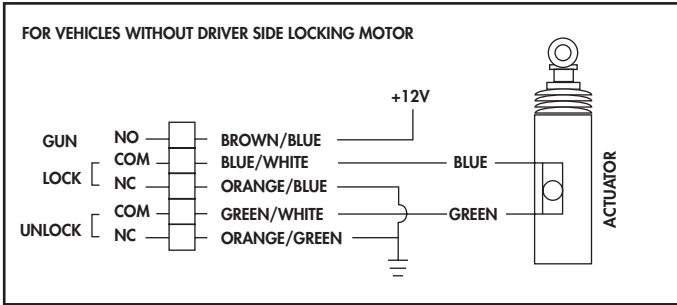

This system has a switch instead of an actuator in the drivers door. You will need to mount an actuator (GT series) in the drivers door to control your locks. Wiring diagram comes with actuator (GT series)

1. Install the fuse on the red wire then connect the BROWN/BLUE, and RED wires to a constant 12 volts.
2. From the keyless entry unit connect the ORANGE/BLUE, ORANGE/GREEN, and BLACK wires to metal ground.
3. Mount the actuator, and connect the BLUE/WHITE and GREEN/WHITE wires to the actuators green and blue wires.

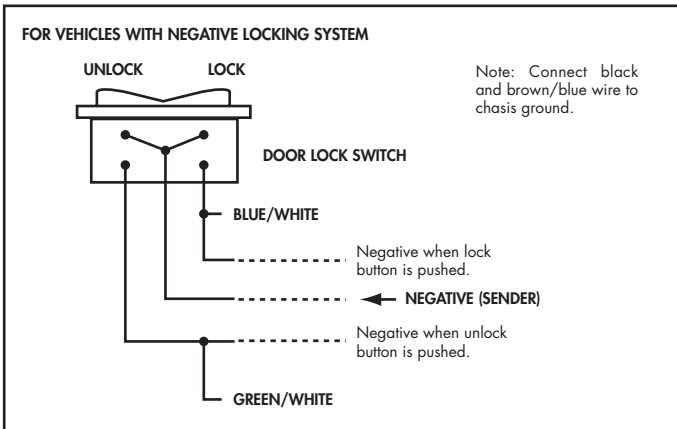

Testing (w/an airbag safe digital volt-ohm meter)

Connect the testlight wire to a ground (-), then probe all wires from your door lock switch to determine the lock, unlock, and sender wires.

1. If you come to a wire that LOCKS your doors when probed (-), then you have found the lock wire. Connect the BLUE/WHITE wire from the keyless entry unit to this wire.
2. If you come to a wire that UNLOCKS your doors when probed (-), then you have found the unlock wire. Connect the GREEN/WHITE wire from the keyless entry unit to this wire.
3. From the keyless entry unit connect the BROWN/BLUE wire to your sender wire. This wire will be a constant "-".
4. Install the fuse on the red wire then connect the RED wire to a constant 12 volts (+), and the BLACK wire to a body ground.

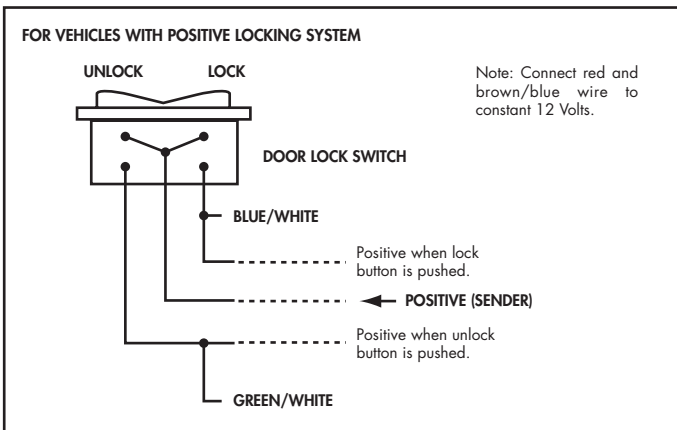

Testing (w/an airbag safe digital volt-ohm meter)

Connect the testlight wire to a 12 volts (+), then probe all wires from your door lock switch to determine the lock, unlock, and sender wires.

1. If you come to a wire that LOCKS your doors when probed (+), then you have found the lock wire. Connect the BLUE/WHITE wire from the keyless entry unit to this wire.
2. If you come to a wire that UNLOCKS your doors when probed (+), then you have found the unlock wire. Connect the GREEN/WHITE wire from the keyless entry unit to this wire.
3. From the keyless entry unit connect the BROWN/BLUE wire to your sender wire. This wire will be a constant "+".
4. Install the fuse on the red wire then connect the RED wire to a constant 12 volts (+), and the BLACK wire to a body ground.

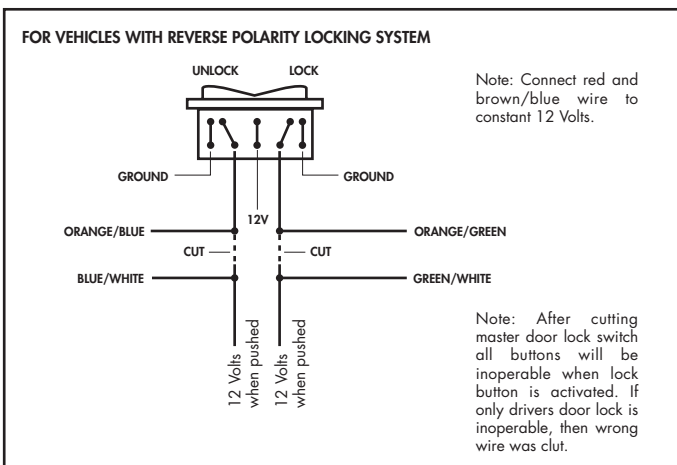

Similar to positive trigger, but will have 5 wires. 2 wires will be grounded, another 2 wires will be positive triggers, and 1 will have a constant 12 volts (sender wire).

1. Install the fuse on the red wire then connect the BROWN/BLUE, & RED wires to 12 volts.
2. From the keyless entry unit connect the BLACK wire to metal ground.
3. Cut the drivers door lock wire. This wire will have 12 volts when lock button is pushed.
4. Connect the ORANGE/BLUE wire to the switch's side of the lock wire.
5. Connect the BLUE/WHITE wire to the motor's side of the lock wire.
6. Cut the drivers unlock wire. This wire will have 12 volts when unlock button is pushed.
7. Connect the ORANGE/GREEN wire to the switches side of the unlock wire.
8. Connect the GREEN/WHITE wire to the motor's side of the unlock wire.

**LOW CURRENT SOLENOIDS & ACTUATORS**

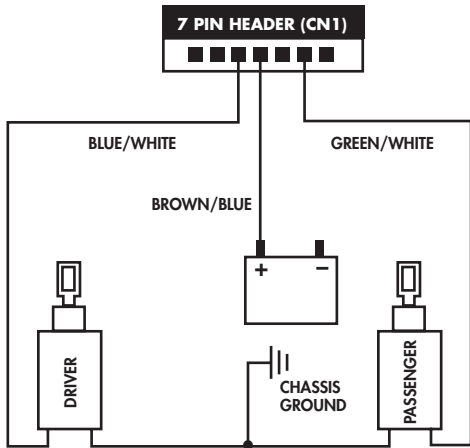

**HIGH CURRENT DRAW SOLENOIDS (SL35/50)**

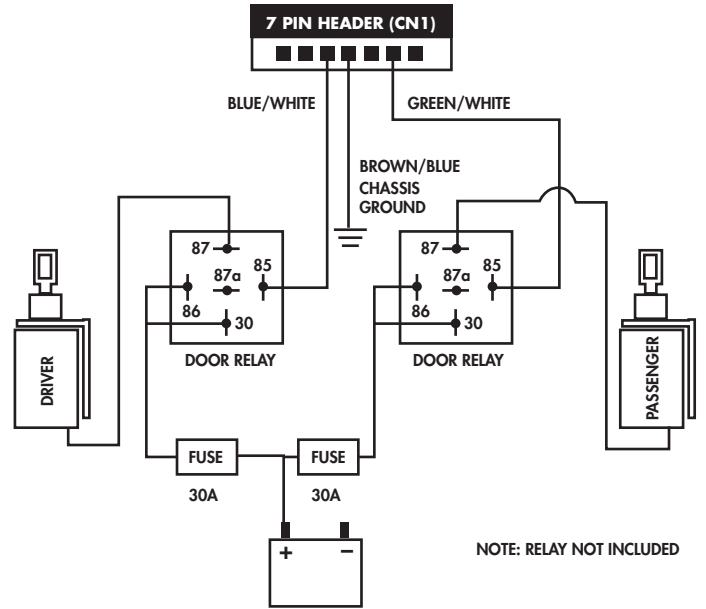

**NEGATIVE OUTPUT TO POSITIVE OUTPUT**

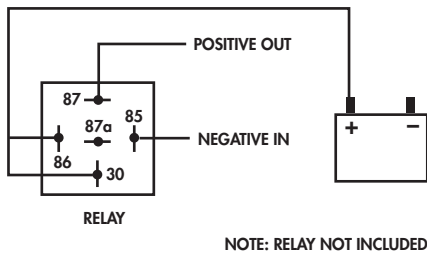

**TRUNK/SHAVED DOOR HANDLE TRIGGER**

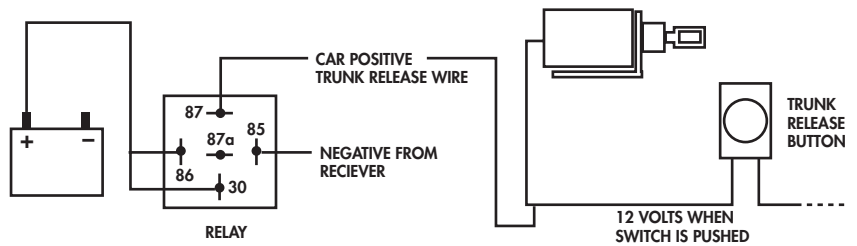

**PARKING LIGHTS**

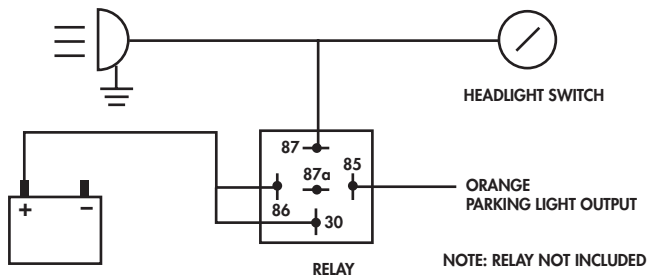

NOTE: If parking lights are negative trigger, then connect 30 to chassis ground.



TECH SUPPORT HOTLINE: 503.693.1918

WWW.AUTOLOC.COM