



If you need further information
or assistance, please contact
your Stromberg dealer,
or e-mail us direct at:

tech@stromberg-97.com

or log on to our Tech Center at:
stromberg-97.com



SSP 9014V4



STROMBERG e-FIRE OWNER'S MANUAL

Made by Stromberg in England

MODELS 11A/21A

THANK YOU

for choosing a Genuine Stromberg e-FIRE electronic distributor for your Flathead Ford. This Owner's Manual will make installation and adjustment as safe and trouble free as possible. It contains several warnings, cautions and notes. Please read them all. It also includes important information about the Stromberg warranty and what to do if you need help.

If you experience any difficulties with distributor installation & timing, please check the detailed Troubleshooting section of this manual first. There is help available at the Stromberg Tech Center: **www.stromberg-97.com**. And you can contact us direct: **tech@stromberg-97.com**

READ THIS FIRST

WARNINGS AND NOTES:

These instructions must be read and fully understood before beginning installation. If these instructions are not fully understood, installation should not be attempted. Failure to follow these instructions, including illustrations, may void your warranty and may result in poor performance, vehicle damage, property damage, severe personal injury or death. If you need information or assistance, please contact your Stromberg dealer or email us direct: **tech@stromberg-97.com**

WARNING:

Correct distributor installation and set up is critical to engine performance, so a thorough knowledge of vehicle mechanical and electrical systems is required. Stromberg recommends installation by a professional mechanic only. An improperly installed or adjusted distributor may void your warranty and may cause poor engine performance or damage, property damage, personal injury, or death.

WARNING:

This e-FIRE distributor (12v negative or 6v positive ground) should be used with a 1.5 Ohm (Ω) coil. Coils with a higher Ohm rating (often called 'internally resisted') will reduce power to the ignition module leading to unreliable performance. Remove or bypass any external ballast resistor or resistor wire. If your engine has a starter bypass wire, you can leave it in place. DO NOT use a low resistance or HEI coil. A coil with LESS than 1.5 Ohms resistance could cause the ignition module to overheat, misfire and fail prematurely. This will invalidate the warranty.

WARNING:

This distributor is not designed for use with engines or transmissions requiring computer-control. Use with these applications may cause damage. This distributor is not designed for MARINE or AIRCRAFT applications.

NOTE: This product is legal only for off-road use or for use on pre-emission controlled motor vehicles/engines. In the USA, this means pre-1966 domestic vehicles certified to California standards, pre-1968 domestic vehicles certified to federal standards and all pre-1968 foreign vehicles.

WARNING:

Before installation, verify that all mechanical and electrical systems are in good working order. These include engine components like intake manifold and gaskets, electrical components including, but not limited to, spark plug wires, battery, battery cables, starter and starter solenoid, and fuel system including fuel tank and fuel lines. Any damaged or improperly operating components must be replaced prior to installing the distributor. Failure to do so may result in poor performance, property damage, serious personal injury or death.

1. PRE-INSTALLATION CHECKLIST

A) Inspect your new Stromberg e-FIRE distributor for possible shipping damage. Check you have the correct model for your application. Model details are clearly marked on the distributor packaging and ID plate.

WARNING:

DO NOT proceed unless your vehicle's electrical system matches that clearly marked on your new e-FIRE distributor. The wrong polarity will cause the e-FIRE ignition module to fail and void your warranty.

B) Stromberg recommends the use of a traditional, points style 1.5 Ohm ignition coil for both 12v and 6v e-FIRE distributors. That's 1.5 Ohm primary resistance measured across the low tension positive and negative terminals. 1.5 Ohm coils are sometimes called 6v or 9v coils, though in practice, ignition coils are not designed for a specific voltage input. Please refer back to the previous page for further advice.

C) With a 12 volt e-FIRE model, battery voltage measured at the coil's positive terminal with the engine running, must not exceed 14 volts at any RPM level. With a 6 volt model, aim for no more than 8 volts in the charging circuit, under no load (ie. no lights, no heater etc.)

WARNING:

Excessive voltage can lead to overheating and ignition module failure.

D) DO NOT use solid core (typically copper) spark plug wires, which do not suppress Electromagnetic/Radio Frequency Interference (EMI/RFI) and can damage the e-FIRE ignition module. Stromberg recommends e-FIRE high performance spark plug wires.

E) Unlike a points distributor, electronic ignition needs a reliable, independent power feed and quality ground (earth) connections. On 6 volt models, choose a power source as near to the ignition key as possible. Check all ground connections and even run an additional engine ground if required.

F) If your engine has a starter bypass wire, you can leave it in place.

USE E-FIRE HIGH PERFORMANCE SPARK PLUG WIRES.

Designed for optimum performance with your e-FIRE electronic distributor, Stromberg e-FIRE spark plug wires mix strong fire power with high level RFI/EMI resistance. The spiral-wound, stainless steel suppression core is protected by tough fiberglass reinforcing braid for strength and flexibility. And the 100% silicone insulation resists high temperatures, moisture, oil and chemicals, and protects against arcing and voltage leaks. With low 500 Ohm/ft resistance, they get more energy into your plugs too.

For easy installation, the 90-degree cap terminals and boots are pre-fitted for smarter 'distributor first' installation. This also leaves you free to use the supplied 90-degree spark plug boots or choose your own hot rod terminals. All leads are designed to fit through your flathead plug wire looms or tubes, and they're cut to length, too, with an extra-long coil wire to reach your firewall.



2. REMOVE EXISTING DISTRIBUTOR

WARNING:

Always disconnect your vehicle's battery, making sure the ignition is off and the engine is cool before performing any work. Failure to do so may result in sparks or burns, and cause a fire or explosion, resulting in property damage, serious personal injury or death.

A) Disconnect the vehicle's battery. Remove the condenser and any radio suppressors. They are not required nor compatible with the Stromberg e-FIRE distributor.

B) Disconnect the distributor low tension wire at the coil. Disconnect the high tension spark plug

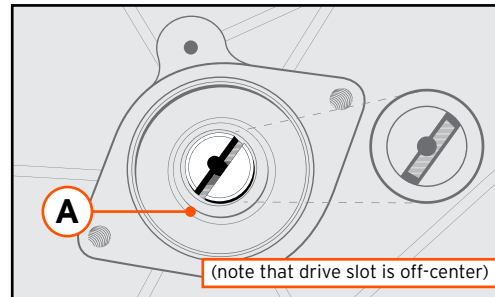

leads and remove the distributor cap. It may be helpful to mark each lead to aid replacement on the new distributor.

C) Carefully disconnect the vacuum advance line, if fitted. It is not required for the new e-FIRE distributor. Plug any threaded holes left in the intake manifold. The corresponding hole in the timing cover can be left unplugged.

D) Unbolt and remove the distributor from the front of the engine. Remove all traces of the old gasket from the mounting flange.

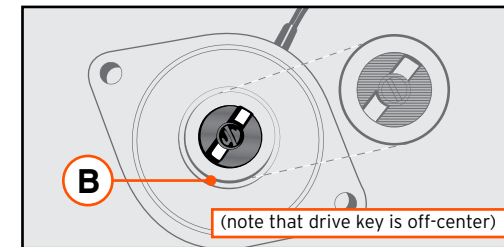

3. INSTALL NEW DISTRIBUTOR

A) Verify that the timing cover distributor mounting surface is clean and flat. Make a note of the position of the offset slot on the end of the camshaft or cam drive adapter (see A) and turn the offset distributor drive key (see B) to approximately match before you offer the distributor onto the engine.

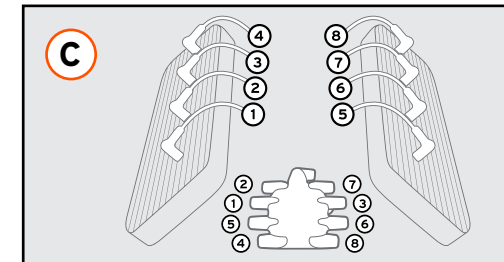

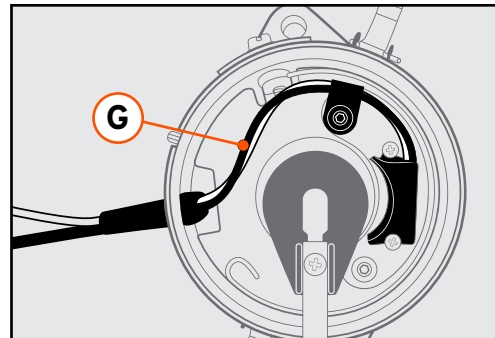
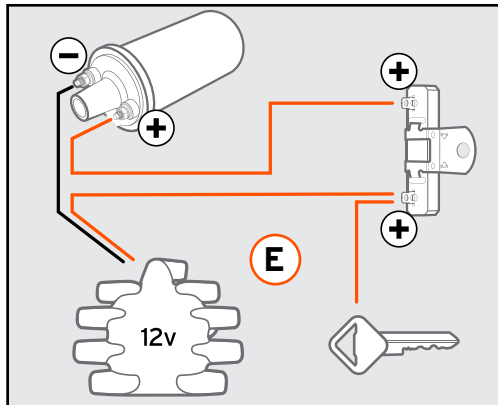
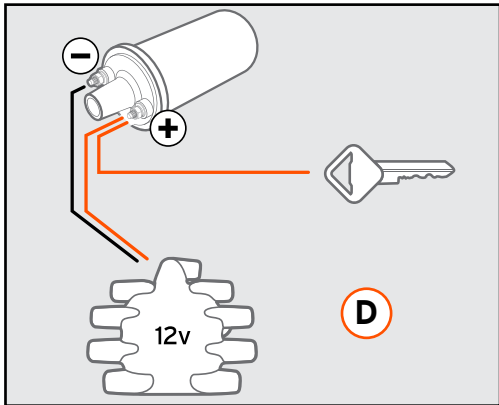

B) Install the Stromberg e-FIRE distributor, with its gasket (supplied) onto the front of the engine, engaging the distributor drive key into the offset slot on the end of the camshaft or cam drive adapter. Note that the drive key and camshaft slot **MUST** align to center the distributor on the mount. It is easier to install if you remove the distributor cap and turn the rotor arm to help align and engage the drive key in the slot.

C) Install the mounting bolts and washers. Do **NOT** over tighten the fasteners. Check that the distributor sits flat on the mounting surface.

D) Connect the spark plug leads, matching the numbers marked on the distributor cap to their correct cylinder locations (see C). The firing order (1-5-4-8-6-3-7-2) and cylinder numbers are the same for all front-mount Ford Flathead distributors from 1932 through 1948. Remember that the distributor turns counterclockwise.

E) The 12 volt negative ground e-FIRE distributor has red and black low tension wires. Connect the

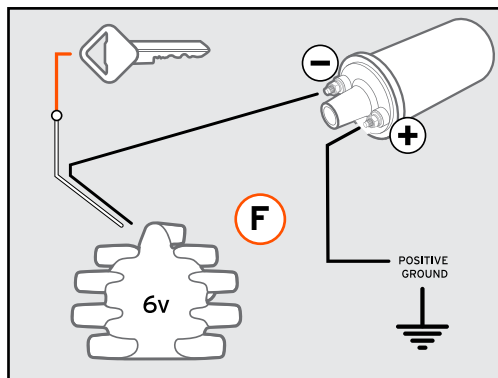

black wire to the negative (-) side of the ignition coil. Connect the red wire to the positive (+) side of the ignition coil or other power source controlled by the ignition switch. (see D)

F) If your ignition has a primary circuit ballast resistor or wire, connect the red wire to the ignition switch side of the ballast resistor. If the position of the ballast resistor or wire is not known, connect the red wire direct to the ignition switch or to a switched live on the fuse box - on the key side of the fuse. (see E).

G) On a 6 volt positive ground model, remove the ignition switch (power) wire from the negative (-) coil terminal and connect the black module wire to the same negative terminal. Connect the white wire to that ignition switch power wire. **DO NOT** attach the white wire to the ignition coil. (see F). Connect an insulated AWG 20 copper stranded wire from the positive coil terminal direct to a good quality chassis ground.

Note: Most early Ford 6 volt positive ground coils were ballast resisted. If possible connect the white module wire to the switched ignition side of the resistor (often located under the dashboard).

H) Terminals are supplied. Use standard auto wire - 20 gauge (1.5mm) 15 amp - to lengthen any wires. Crimp tightly or solder (best) the joints and insulate all connections. Do not pull on the wires

causing them to tighten inside the distributor cap. The wires must allow movement of the timing adjustment plate, yet not interfere with any moving parts (see G).

WARNING:

DO **NOT** reverse the polarity of the wires from the advice above. It will damage the ignition module irreparably and void the warranty.

I) The 12 volt negative ground e-FIRE distributor is compatible with most Capacitor Discharge Ignition units. Follow the manufacturer's instructions, connecting the black wire to the CDI unit as if connecting your low tension wire. The red wire is connected to the same switched power source as the CDI unit. **DO NOT** connect the red wire to the coil. 6 volt positive ground models are **NOT** compatible with CDI units.

4. START THE ENGINE

WARNING:

If your vehicle has a manual transmission, verify that it is in neutral gear with the parking brake on before starting. With an automatic transmission, confirm that it is in 'park' before starting. Failure to do so may result in unintended vehicle movement causing property damage, serious personal injury, or death.

A) Reconnect the battery and start the vehicle as usual. Run the engine to full operating temperature, then check it idles and revs freely and take it for a test drive. While Stromberg e-FIRE distributors for Ford flatheads are factory pre-set to match OE timing, some fine tuning may be required for local gasoline and individual engine specification. If you suspect any problems, stop the engine immediately and refer to Section 6, Troubleshooting.

- B)** Pay particular attention to any knocking, pinking or detonation sound under engine load, which may indicate too much timing advance. If so, stop the vehicle, retard the static timing a little (see H) and test again.

WARNING:

Too much distributor advance can cause engine detonation, which can damage an engine very quickly. If you hear detonation, stop the engine immediately and retard the timing.

WARNING:

Do not leave the ignition switched on when the car is not running, as this can cause permanent overheating damage to the coil and ignition module.

5. ENGINE TIMING

- A)** Stromberg e-FIRE 11A and 21A distributors are set to 4 degrees static advance at idle, with a further 22 degrees maximum mechanical advance at around 2600rpm. Different settings may be required for non-standard engines and differences in local gasoline.
- B)** Static timing adjustment can be made using the timing screw on the side of the distributor. Loosen the screw (see H) then slide it clockwise (down) to advance engine timing or counter-clockwise to retard. The adjustment is sensitive. Each mark on the adjustment plate will change the timing 4 degrees of crankshaft rotation (2 degrees on a distributor machine).

WARNING:

Always stop the engine before adjusting distributor timing. Failure to do so may result in property damage, severe personal injury or death.

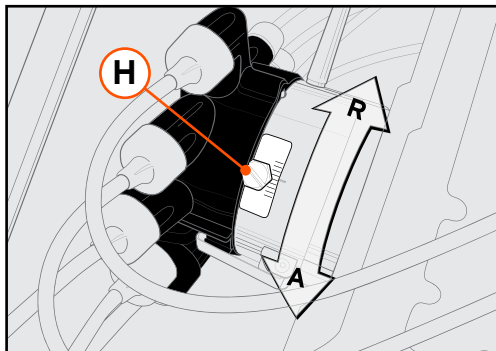

- C)** For advanced tuning, the Stromberg e-FIRE distributor also allows adjustment of the total mechanical advance and advance curve. Please visit the Stromberg Tech Center at www.stromberg-97.com for further advice.

6. TROUBLESHOOTING

Every single e-FIRE distributor is factory-tested before shipping to check advance from idle up through the rpm range, and high tension function to the spark plugs. Experience has shown that our ignition modules are very robust. So if you have a problem, please read this before contacting Stromberg or your dealer.

- A)** If the engine will not start after installation, begin with the usual diagnostics. Are your plug wires connected properly? Do you have fuel? Is there a spark out of the coil into the cap? If the engine runs, but won't pick up, do you need to adjust the timing?
- B)** Your old points distributor may run fine with weak input voltage, but any electronic distributor

will struggle without a reliable power source and a good ground (earth). This is VERY important, especially on 6 volt models where under-charged batteries, hidden ballast resistors, high-resistance coils, old wiring and worn starter motors can leave your e-FIRE without the power it needs. Please check it still gets a good 6 or 12 volts WHEN CRANKING the starter.

- C)** The above also applies if the engine runs roughly, especially at higher rpm. If so, use a jumper cable to connect the e-FIRE power wire direct to the battery. If running improves, this usually indicates low voltage to the module, often caused by a ballast resistor or a high Ohm coil. So try connecting the power wire to a more direct source, like the ignition switch. And/or swap the coil to the recommended 1.5 Ohms. **Performance will also be compromised if the ground (earth) is poor. So check for good continuity from the e-FIRE module mounting plate to ground.**
- D)** Remember, too, that the electronic module is a switch for the coil. It does not govern spark strength. And if it sparks to one plug, it should spark to them all.
- E)** If at any point the module is wired incorrectly, supplied with excess voltage or the polarity reversed, it may fail and void your warranty. For further troubleshooting tips, visit the Stromberg Tech Center at: www.stromberg-97.com
- ## **7. MAINTENANCE**
- A)** The Stromberg e-FIRE distributor requires very little maintenance. After an initial running period, check and retighten all bolts and screws, as required. Check all electrical connections including the spark plug wires.
- B)** Further down the road, a little annual aftercare can pay dividends. A single drop of light oil on

the felt pad under the rotor will help keep the advance plate moving, for example. And while you should aim to keep water and road salt out of the distributor, it is known that air inside any distributor can become ionised and attract moisture which can cause corrosion over time. All of the e-FIRE steel internal parts are zinc plated, but a light spray of water displacement lube to the advance mechanism (under the module plate), will help keep the advance weights moving as they should.

- C)** Stromberg e-FIRE service parts are recommended for reliable fit and service life. Always use Stromberg e-FIRE ignition modules.

8. WARRANTY

All Stromberg products receive numerous checks and tests to ensure optimum quality and performance. Stromberg also takes customer support very seriously, and this extends to fair Limited Warranty terms and procedures across our full product range as outlined below.

Stromberg warrants its new products to be free from defects in material and workmanship for one (1) year from the date of original purchase by the Purchaser.

Limited Warranty

STROMBERG PROVIDES NO WARRANTY EITHER EXPRESS OR IMPLIED OTHER THAN THIS LIMITED WARRANTY. STROMBERG EXPRESSLY DISCLAIMS ALL IMPLIED WARRANTIES OF ANY KIND INCLUDING, BUT NOT LIMITED TO, MERCHANTABILITY AND FITNESS FOR A PARTICULAR PURPOSE. IN NO EVENT SHALL STROMBERG OR ITS AGENTS, EMPLOYEES, OFFICERS, DIRECTORS, RELATED ENTITIES OR SUCCESSORS, BE LIABLE FOR SPECIAL,

INCIDENTAL, CONSEQUENTIAL, OR PUNITIVE DAMAGES ARISING OUT OF, OR IN CONNECTION WITH, PRODUCTS OR SERVICES SOLD, WHETHER BASED IN WARRANTY, CONTRACT, TORT (INCLUDING NEGLIGENCE AND STRICT LIABILITY), OR ANY OTHER LEGAL THEORY. STROMBERG'S MAXIMUM LIABILITY SHALL NOT EXCEED THE PURCHASE PRICE OF THE PRODUCT. STROMBERG NEITHER ASSUMES, NOR AUTHORIZES ANY OTHER PERSON TO ASSUME FOR US, ANY OTHER LIABILITY IN CONNECTION WITH THE SALE OF THIS GENUINE STROMBERG PRODUCT. STROMBERG DOES NOT WARRANT WHATSOEVER ANY ACCESSORIES OR PARTS SUPPLIED BY OTHER MANUFACTURERS.

Any implied warranty determined to be applicable is limited in duration to the duration of this warranty. This warranty gives you specific legal rights. However, you may also have other rights that may vary from state to state or province. This Limited Warranty constitutes the entire understanding between Stromberg and the Purchaser.

Warranty Procedure

To claim under this Limited Warranty, the Purchaser must:

1. CONTACT US FIRST! You can email us at **warranty@stromberg-97.com**. Most distributor issues are simple and can be addressed quickly with email advice. Please remember to check Section 6. Troubleshooting and look for further advice on the Stromberg Tech Center at **www.stromberg-97.com**
2. If you cannot contact us, contact the place of purchase, providing the dated purchase receipt and a clear description of the problem.
3. If the product needs replacement, we will provide a Return Goods Authorization (RGA) number and an address for return. We will provide a replacement on return of the product so enclose your RGA

number and a return address. NO RETURNS WILL BE ACCEPTED WITHOUT AN RGA NUMBER. No replacements will be shipped without return of the original product.

DO NOT send products directly to Stromberg without our prior notice. Stromberg assumes no responsibility for products sent directly to Stromberg.

Warranty Exclusions

Stromberg does not warrant products which are damaged as a result of improper installation or application, including but not limited to:

1. Failing to follow or deviating from any installation guidance provided by Stromberg, including incorrect wiring, a coil with insufficient resistance, excess voltage, and reversed polarity.
2. Modifying or altering the distributor beyond factory specifications, outside what could be considered tuning for optimum performance.
3. Subjecting the product to adverse conditions, overheating, abuse, neglect, accident, collisions, dirt or contaminants, water or corrosion, or faulty repair; and improper adjustment.
4. Stromberg also does not warrant, and disclaims all liability for, products used for racing, or any non-automotive, marine, or aircraft application or purpose.
5. Please note: Due to the varied and often extreme conditions experienced by front-mount distributors, the Stromberg Limited Warranty excludes the distributor cap on these models. Service parts are available from your Stromberg dealer.

Stromberg is the sole and final judge of whether a product is covered by the warranty. In the event that Stromberg determines that a defect in material

or workmanship exists, Stromberg's responsibility is strictly limited to the repair or replacement of the defective product or parts, as Stromberg elects, and the return of the repaired or replaced product or parts to the Purchaser, freight prepaid. Stromberg has no other obligation, and makes no other warranties - whether express or implied.

As used herein, the term 'Purchaser' shall mean the original purchaser or consumer of the Stromberg product. The Limited Warranty is restricted to the Purchaser. The warranty is not assignable or otherwise transferable.

NOTES:
